

Body-Solid

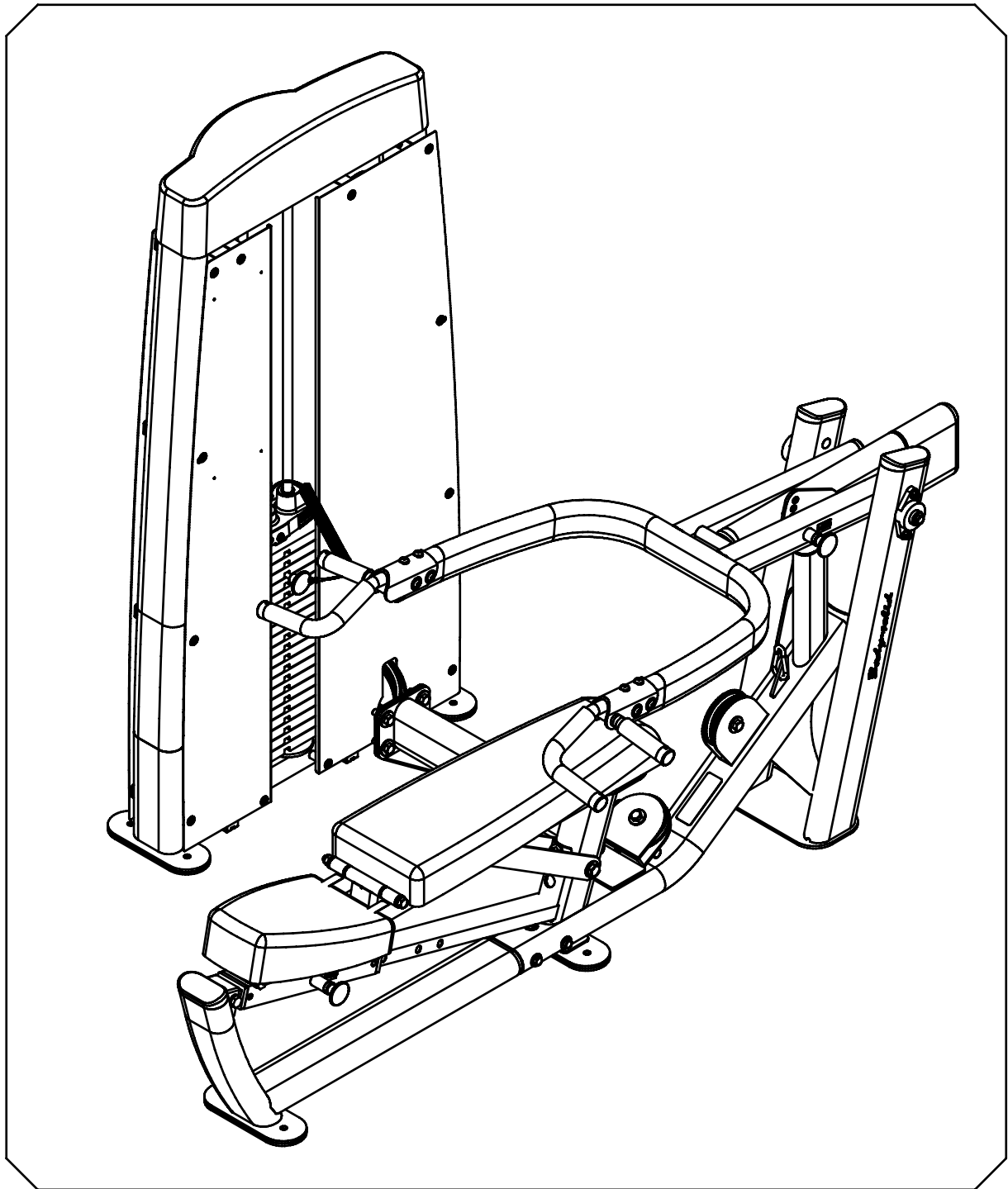

BODY-SOLID, Inc.
1900 S. Des Plaines Ave.
Forest Park, IL 60130 USA
Phone: (708) 427-3555
Fax: (708) 427-3556
www.bodysolid.com

DPRS.1 OWNER'S MANUAL

DPRS ASSEMBLY INSTRUCTIONS

HARDWARE ILLUSTRATION

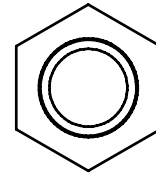
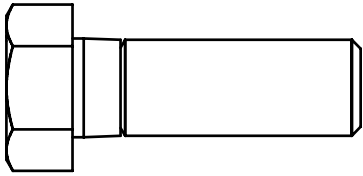

(A1)HEX BOLT 1/2"x1 1/2"L PARTIAL THREAD QTY.7

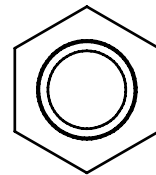
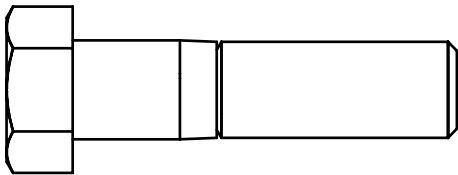

(A2)HEX BOLT 1/2"x2"L PARTIAL THREAD QTY.1

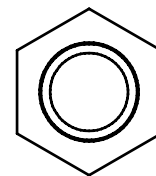
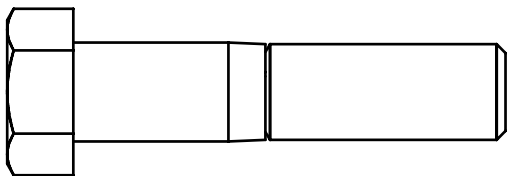

(A3)HEX BOLT 1/2"x2 1/4"L PARTIAL THREAD QTY.1

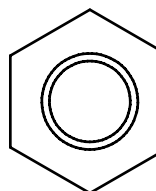
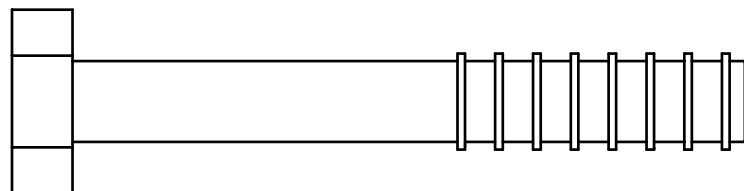

(A4)HEX BOLT 1/2"x3 1/2"L PARTIAL THREAD QTY.1

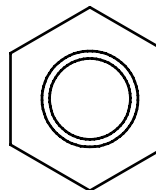
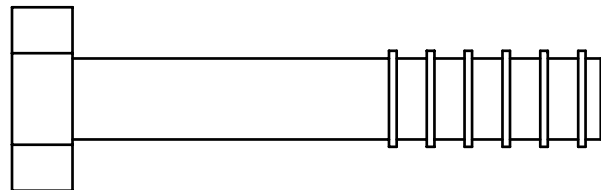

(A5)HEX BOLT 1/2"x2 3/4"L PARTIAL THREAD QTY.1

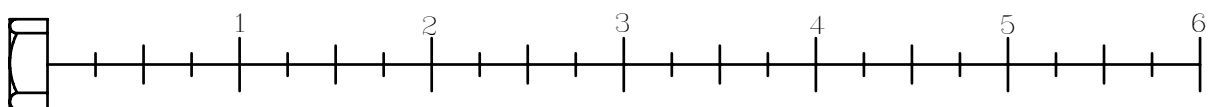

DPRS ASSEMBLY INSTRUCTIONS

HARDWARE ILLUSTRATION

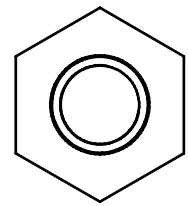
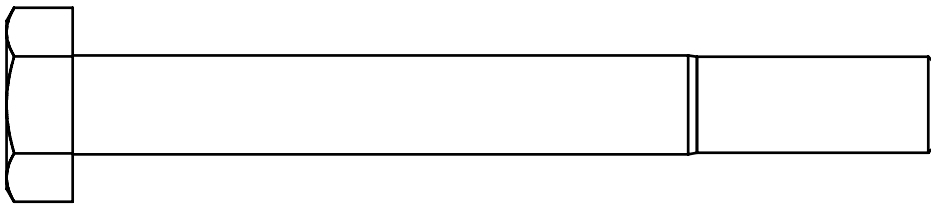

(A6)HEX BOLT 1/2"x4 1/2"L PARTIAL THREAD QTY.1

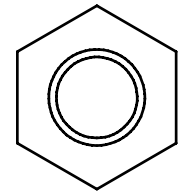
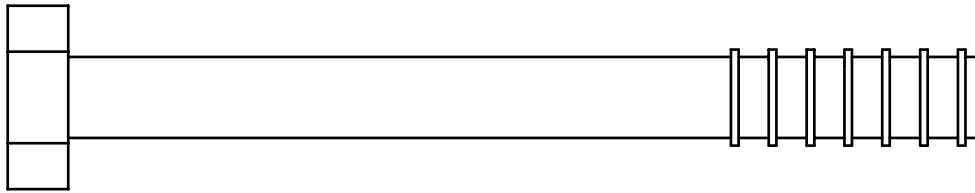

(A7)HEX BOLT 1/2"x4 3/4"L PARTIAL THREAD QTY.1

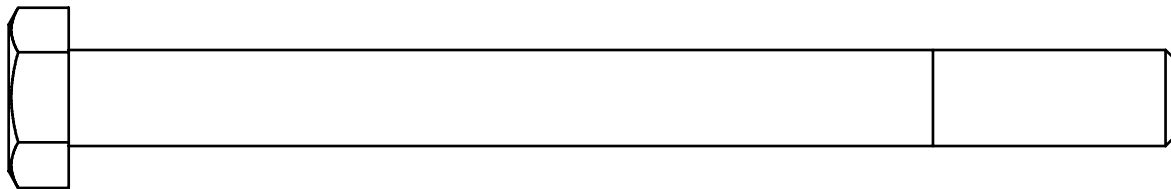

(A8)HEX BOLT 1/2"x5 3/4"L PARTIAL THREAD QTY.1

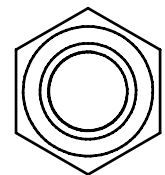
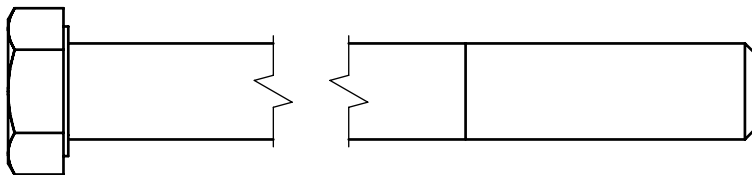

(A9)HEX BOLT 1/2"x7"L PARTIAL THREAD QTY.1

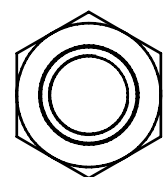
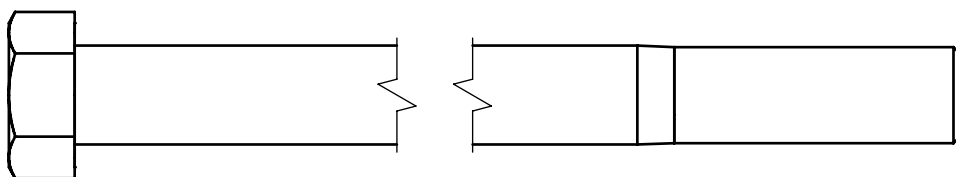

(A10)HEX BOLT 1/2"x8 1/2"L PARTIAL THREAD QTY.1

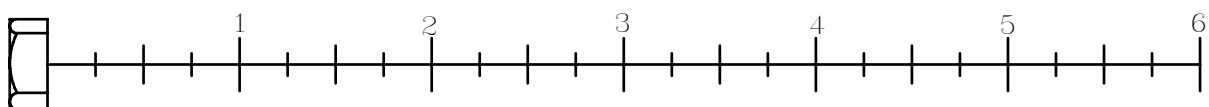

DPRS ASSEMBLY INSTRUCTIONS

HARDWARE ILLUSTRATION

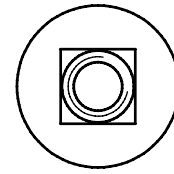
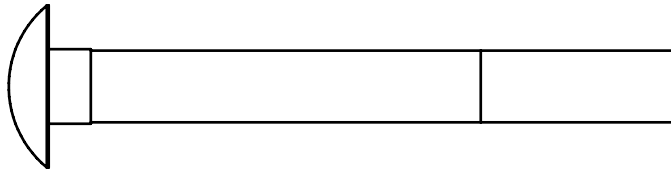

(A12)ROUND ALLEN HEAD 3/8"x3 1/8"L PARTIAL THREAD QTY.4

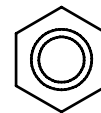
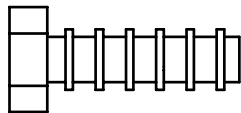

(A13)HEX BOLT 5/16"x1"L PARTIAL THREAD QTY.3

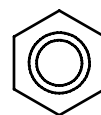
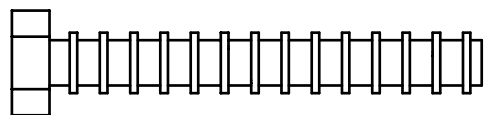

(A14)HEX BOLT 5/16"x2 1/4"L PARTIAL THREAD QTY.4

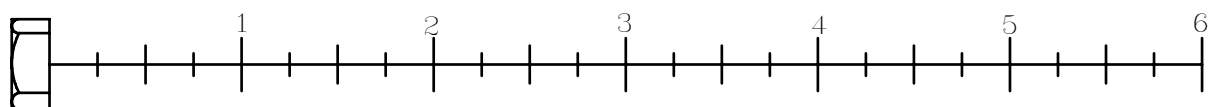

DPRS ASSEMBLY INSTRUCTIONS

FRAME HARDWARE ILLUSTRATION



(A15) ALLEN SCREW 5/16" X 3/8" L FULL THREAD QTY. 3

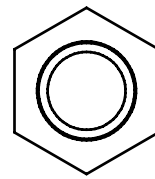
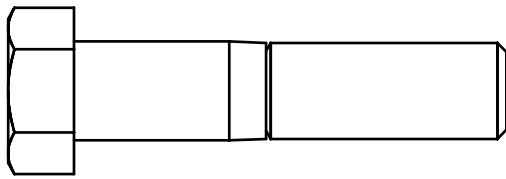

(A16) HEX BOLT 1/2" X 2 1/4" L PARTIAL THREAD QTY. 4

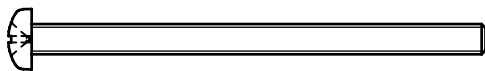

(A17) HEX BOLT M4 X 65 L" L PARTIAL THREAD QTY. 2

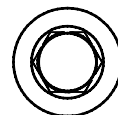
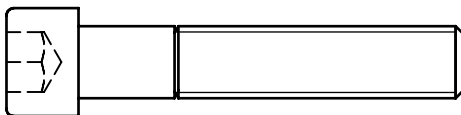

(A18) ROUND ALLEN HEAD 3/8" X 2" L PARTIAL THREAD QTY. 1

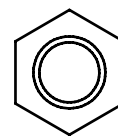
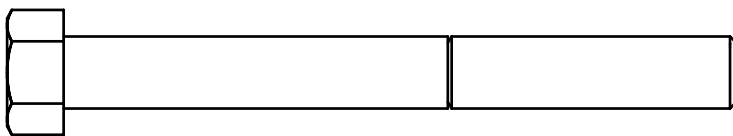

(A19) HEX BOLT 3/8" X 3 1/2" L PARTIAL THREAD QTY. 1

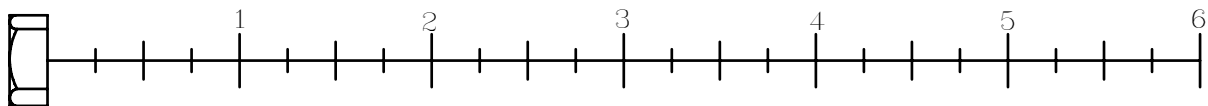

DPRS ASSEMBLY INSTRUCTIONS

FRAME HARDWARE ILLUSTRATION

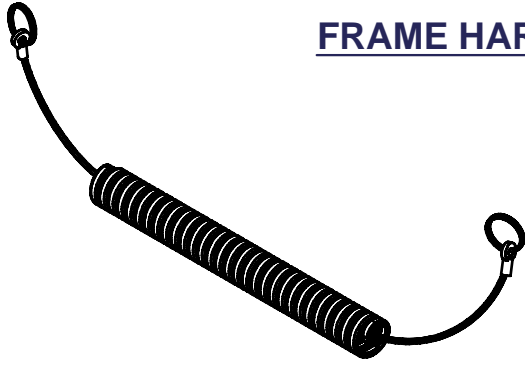

(A20)ELASTIC BOLT QTY.1

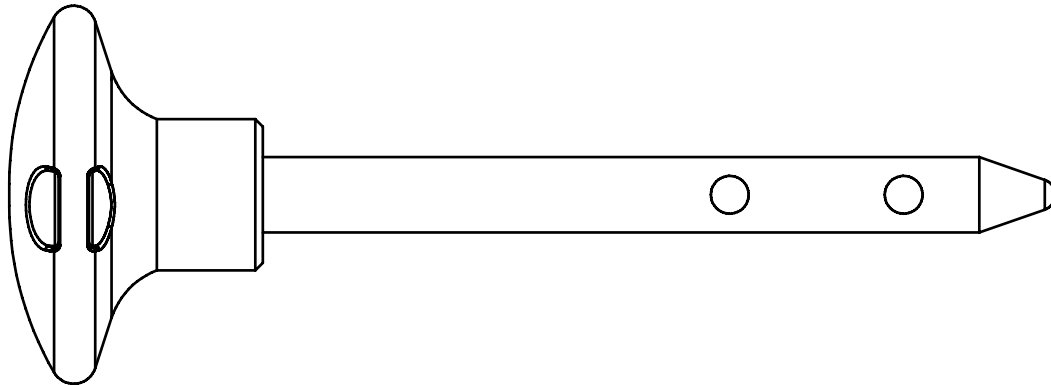

(A21)10LB PIN (8250-071) QTY.1

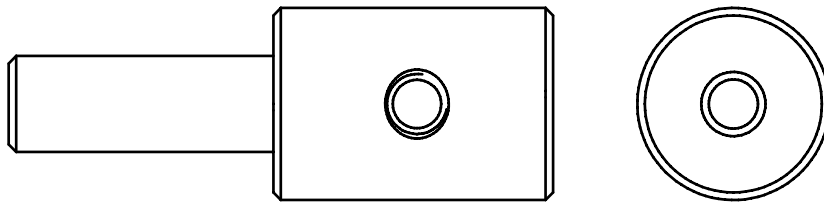

(A22)WEIGHT STACK CABLE (8260-009) QTY.1



(A23)ROUND ALLEN HEAD M6X20L PARTIAL THREAD QTY.20



(A24)ROUND ALLEN HEAD 5/32"X1/4"L PARTIAL THREAD QTY.4

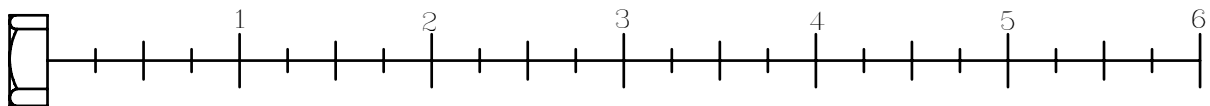

DPRS ASSEMBLY INSTRUCTIONS

HARDWARE ILLUSTRATION

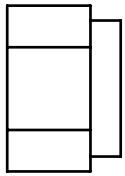

(B1) NYLON LOCK NUT 1/2" QTY.14

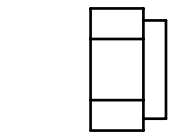
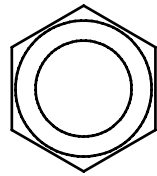

(B2) NYLON LOCK NUT 3/8" QTY.4

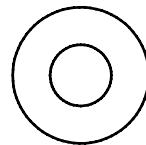
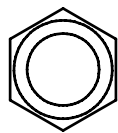

(C5) 5/16" (I.D.) FLAT WASHER \varnothing 18 QTY.7

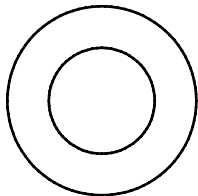

(C1) 1/2" (I.D.) FLAT WASHER \varnothing 25 QTY.6

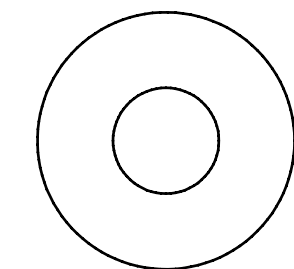

(C2) 1/2" (I.D.) FLAT WASHER \varnothing 34 QTY.23

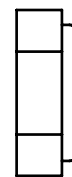
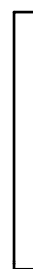

(B6) NYLON LOCK NUT 1/2" X 8H QTY.1

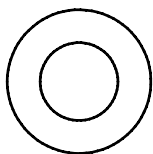
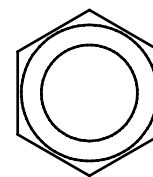

(C3) 3/8" (I.D.) FLAT WASHER \varnothing 19 QTY.4

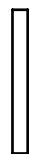

1

2

3

4

5

6

DPRS ASSEMBLY INSTRUCTIONS

FRAME HARDWARE ILLUSTRATION

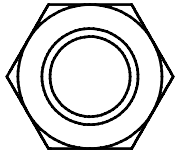

(B3) NYLON LOCK NUT 1/2" X 13 UNC X 8 T QTY. 1

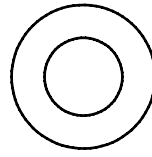
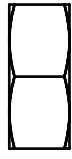

(C9) 3/8" (I.D.) FLAT WASHER Ø19 QTY. 2

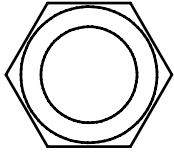

(B4) NYLON LOCK NUT 1/2" QTY. 4

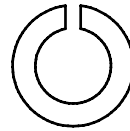
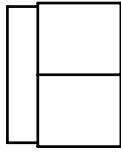

(C10) 3/8" SPRING WASHER QTY. 1

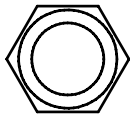

(B5) NYLON LOCK NUT 3/8" QTY. 1

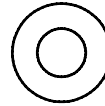
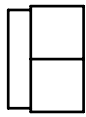

(C11) M6 (I.D.) FLAT WASHER Ø13 QTY. 20

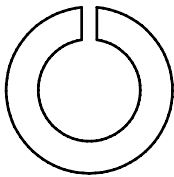
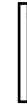

(C7) 1/2" SPRING WASHER QTY. 1

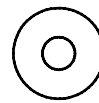

(C12) M4 (I.D.) FLAT WASHER Ø12 QTY. 2

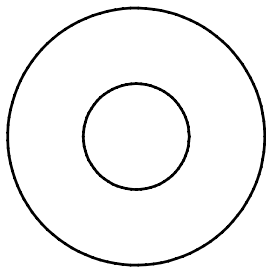

(C8) 1/2" (I.D.) FLAT WASHER Ø34 QTY. 6

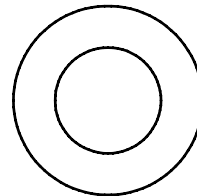

(C13) 1/2" (I.D.) FLAT WASHER Ø25 QTY. 2



DPRS ASSEMBLY INSTRUCTIONS

HARDWARE ILLUSTRATION

D1.	3/4"X16L STEEL BUSHING (8110-066)	[2PCS]
D2.	30X20X1.5T CU WASHER (8520-007)	[4PCS]
D3.	8 SPRING SNAP LINK(8810-001)	[1PCS]
D4.	20X40 END CAP(9211-008)	[4PCS]
D5.	50X75(30X60)NYLON BUSHING(9211-083)	[2PCS]
D6.	58X116 END CAP(9211-112)	[4PCS]
D7.	40X80 END CAP(9211-113)	[2PCS]
D8.	3/4" SHAFT COLLAR(9211-046)	[2PCS]
D9.	4" RUBBER DOUNT(9310-017)	[2PCS]
D10.	95X250 RUBBER PAD(9310-060)	[4PCS]
D11.	40X70 FRICTION TAPE(9440-068)	[2PCS]
D12.	20X120 FRICTION TAPE(9440-083)	[2PCS]
D13.	117 PULLEY(9213-010B)	[7PCS]
D14.	WEIGHT SELECTOR BAR(8210-042)	[1PCS]
D15.	TOP PLATE(8400-006)	[1PCS]
D16.	2420mm STEEL CABLE(FDPRSA)	[1PCS]
D17.	2675mm STEEL CABLE(FDPRSB)	[1PCS]
D18.	DPRS For DGYM Steel Cable(FDPRSC)	[1PCS]
D19.	95X250 RUBBER PAD(9310-061)	[1PCS]

D1



D2



D3



D4

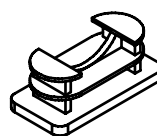

D5

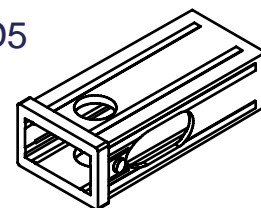

D6

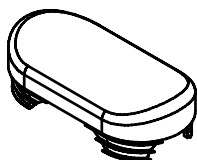

D7

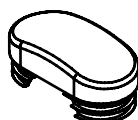

D8



D9

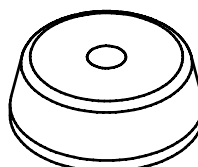

D10

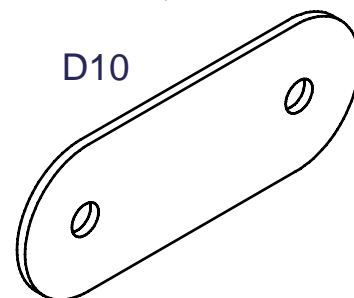

D11

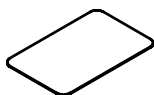

D12

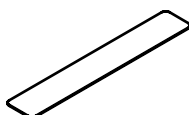

D13

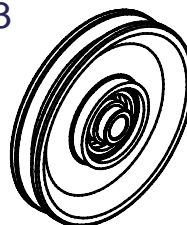

D14

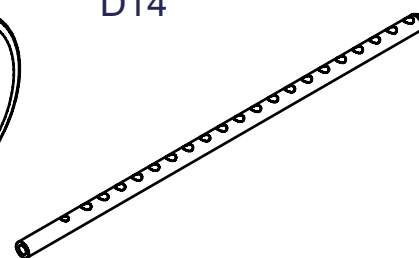

D15

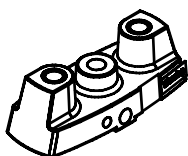

D16

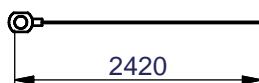

D17

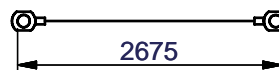

D19

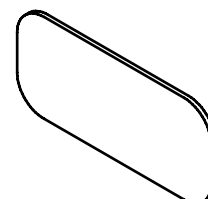

DPRS ASSEMBLY INSTRUCTIONS

PARTS ILLUSTRATION SHEET

A1[1PCS]

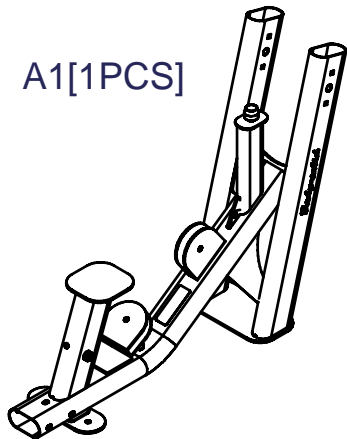

B[1PCS]

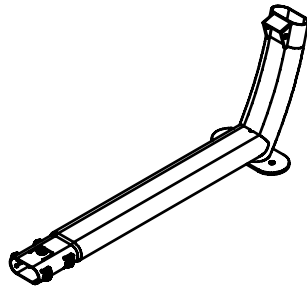

C[1PCS]

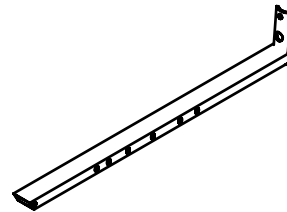

D1[1PCS]

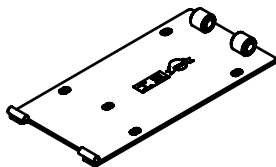

E1[1PCS]

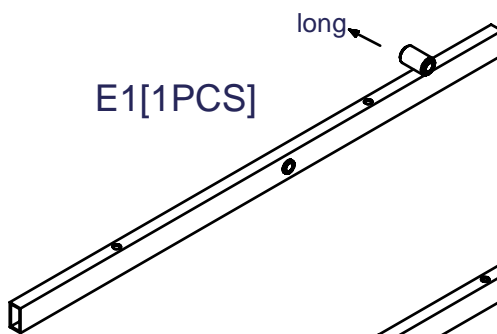

F1[1PCS]

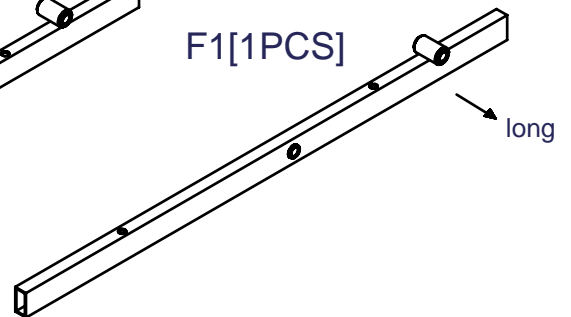

G[1PCS]

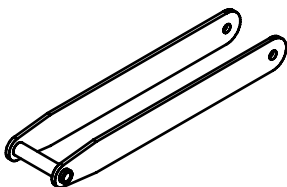

H[1PCS]

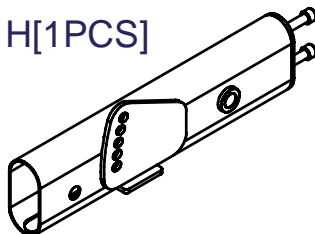

I[1PCS]

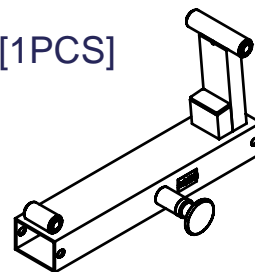

L[1PCS]

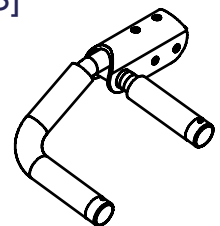

J[1PCS]

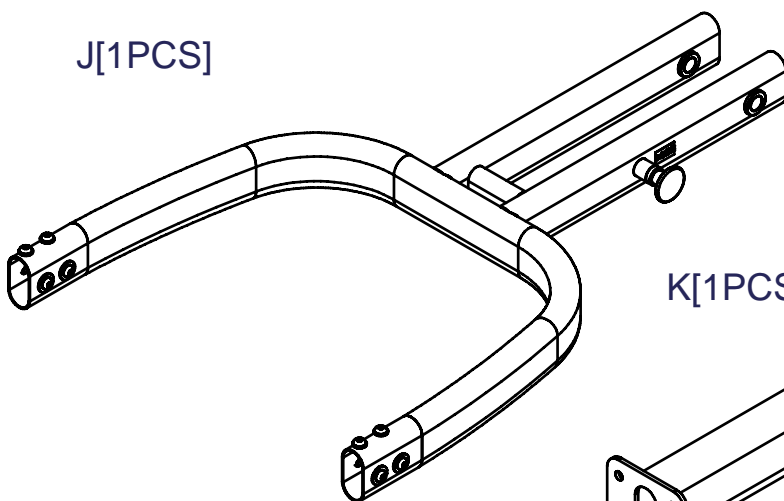

K[1PCS]

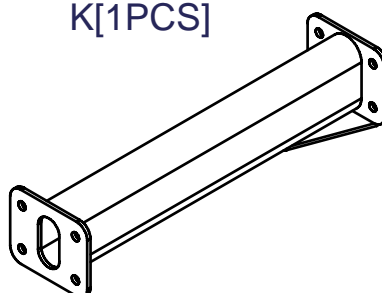

M[1PCS]

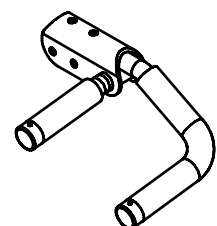

DPRS ASSEMBLY INSTRUCTIONS

PARTS ILLUSTRATION SHEET

N[1PCS]
8220-136
Ø20X360L

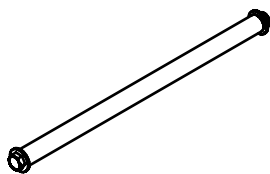

O[1PCS]
8230-009

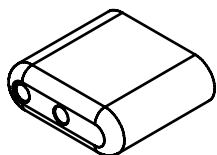

P[1PCS]
6640-001

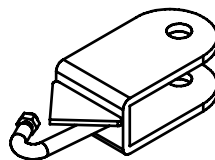

Q[2PCS]
8510-040

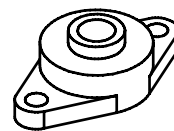

R[1PCS]
9111-059

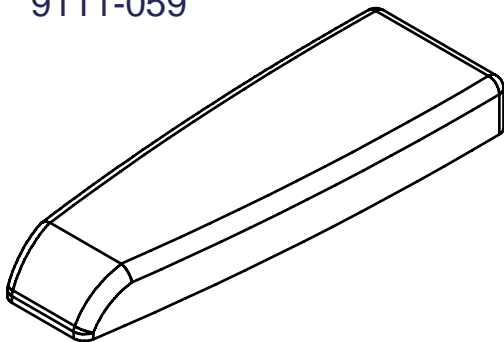

S[1PCS]
9121-056

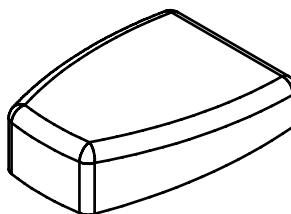

T[1PCS]
9170-002

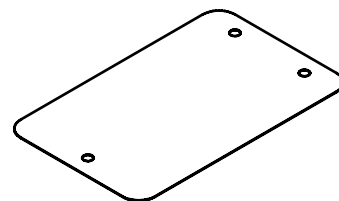

DPRS ASSEMBLY INSTRUCTIONS

FRAME PARTS ILLUSTRATION SHEET

U[1PCS]
8380-046

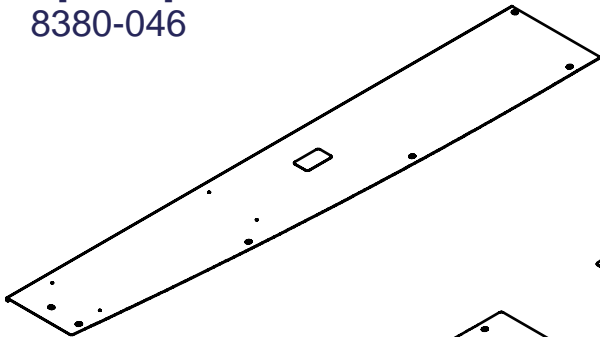

V[1PCS]
8380-048

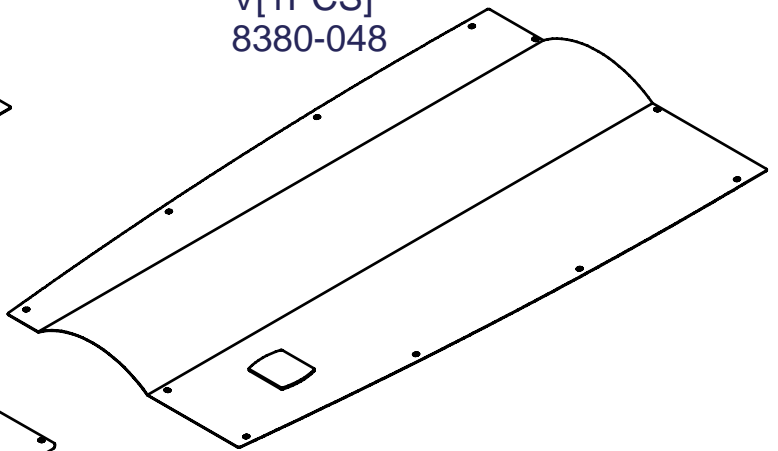

W[1PCS]
8380-047

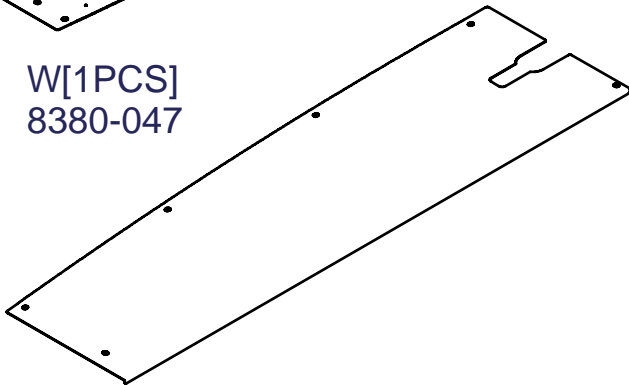

X[2PCS]
Ø3/4"X1410L

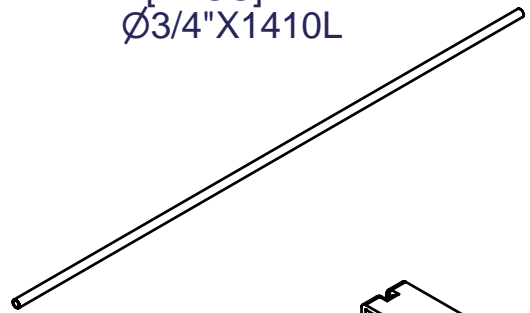

Y[1PCS]
9211-111

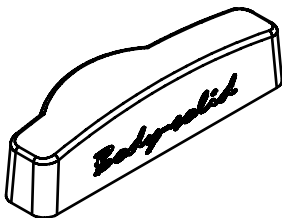

Z[2PCS]
8313-144

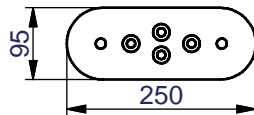

AD[9PCS]
8321-040
both side

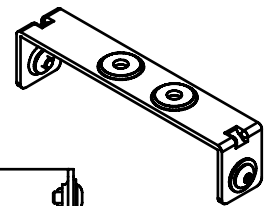
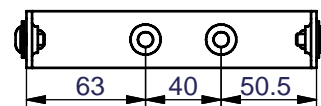

AA[1PCS]
6610-002

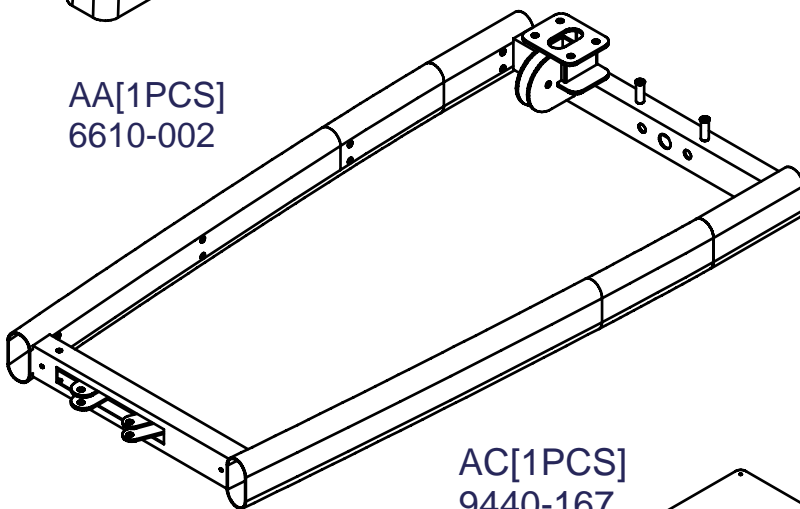

AE[1PCS]
8321-040
one side

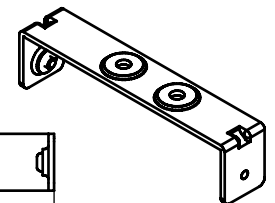
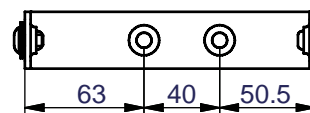

AC[1PCS]
9440-167

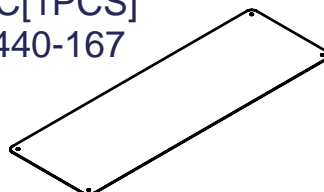

AF[2PCS]
8321-040
one side

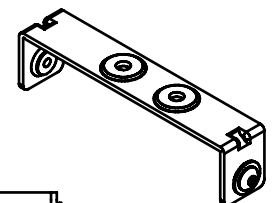
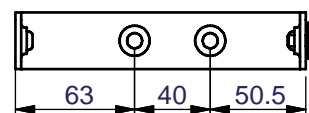

DPRS ASSEMBLY INSTRUCTIONS

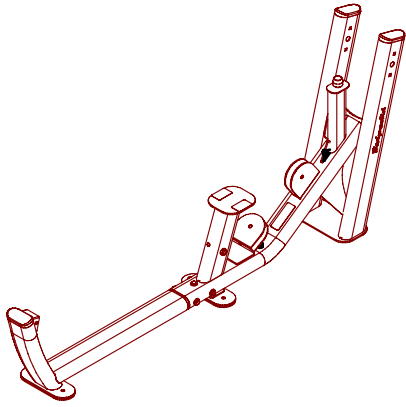

Above shows STEP 1
assembled and completed

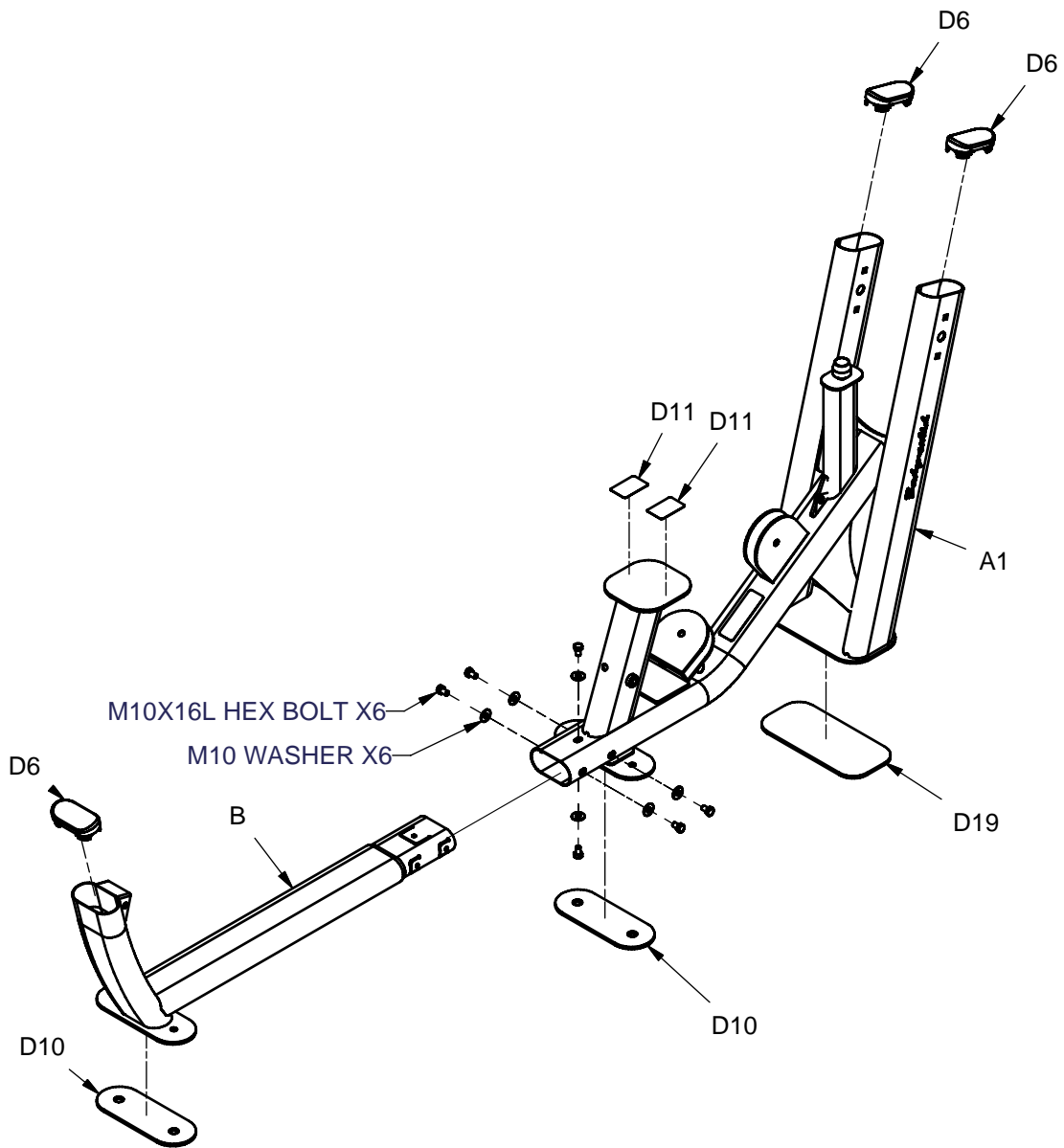

DPRS ASSEMBLY INSTRUCTIONS

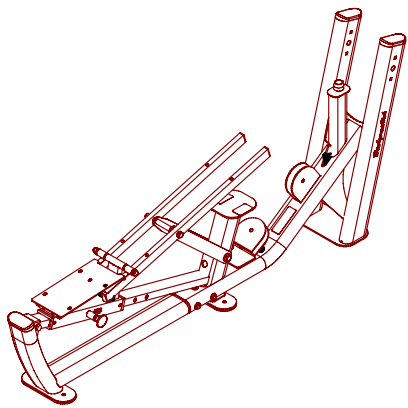

Above shows STEP 3
assembled and completed

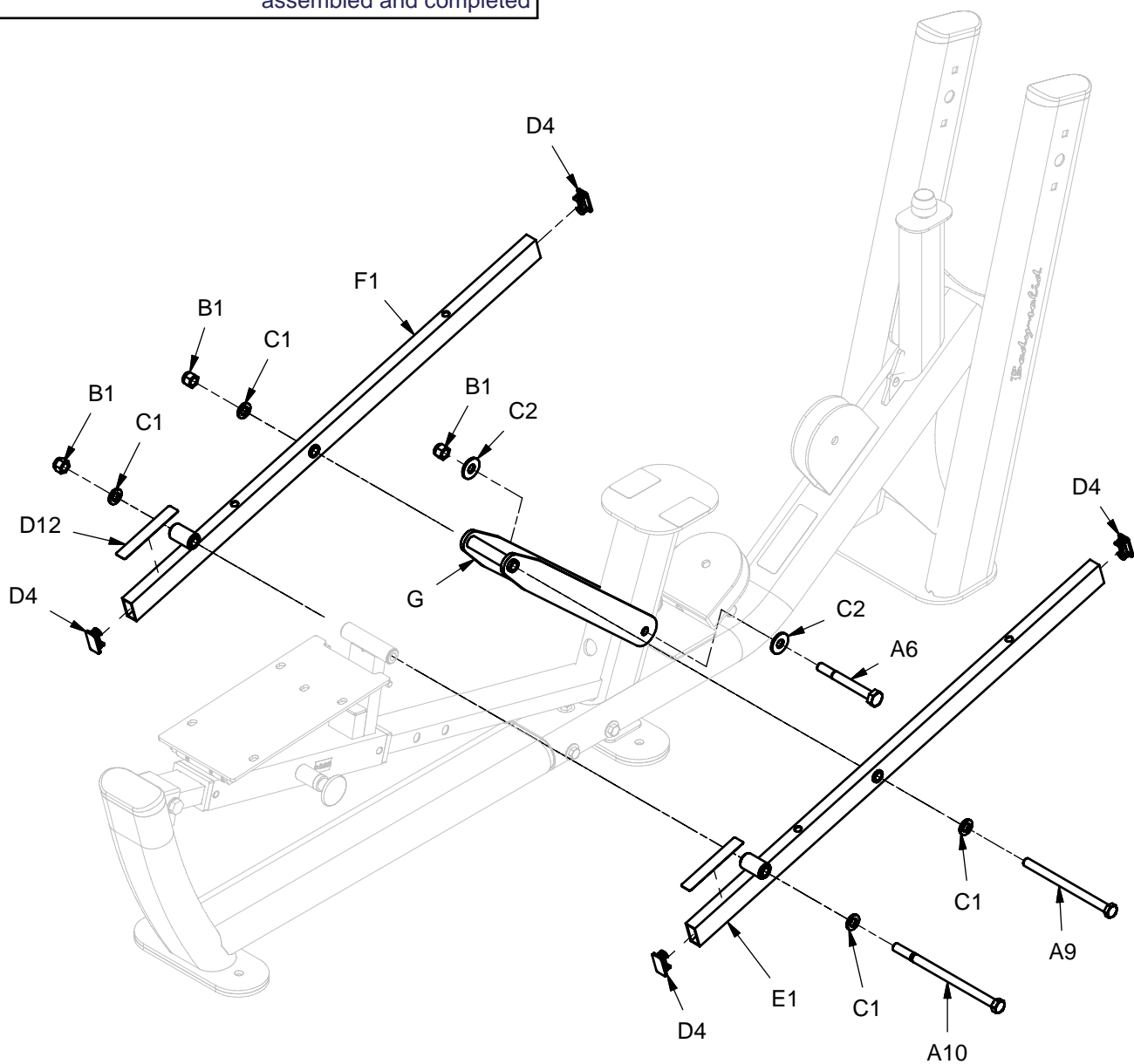

DPRS ASSEMBLY INSTRUCTIONS

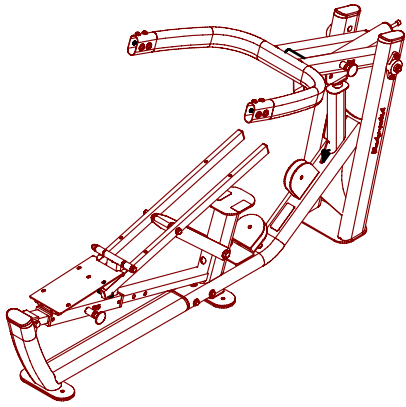

Above shows STEP 4 assembled and completed

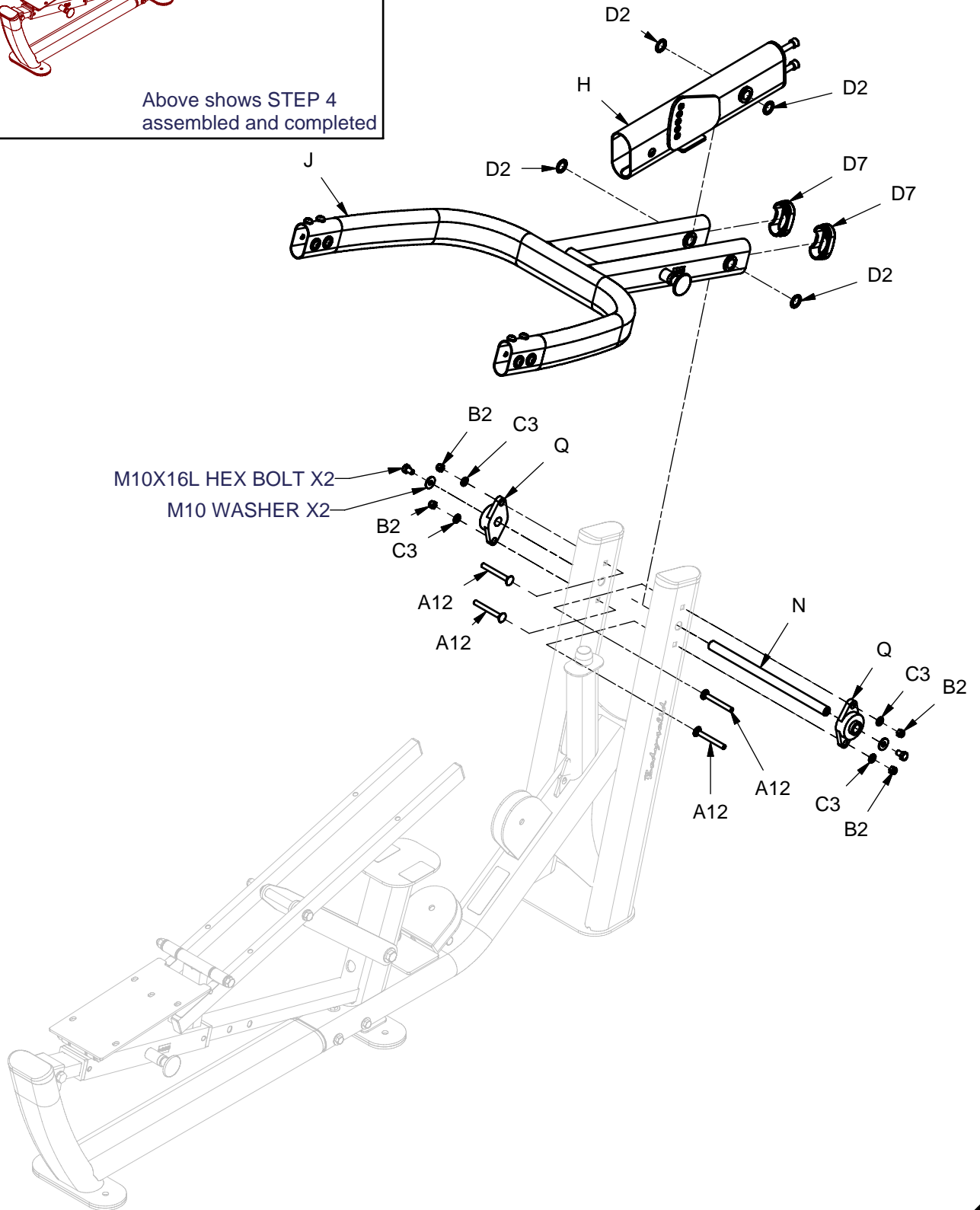

DPRS ASSEMBLY INSTRUCTIONS

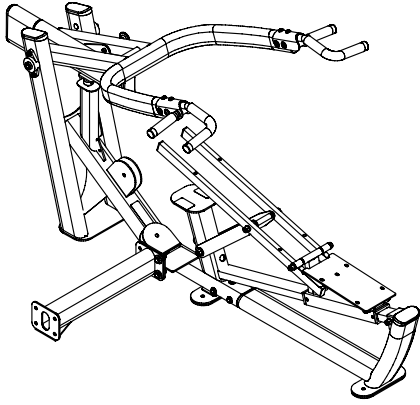

Above shows STEP 5 assembled and completed

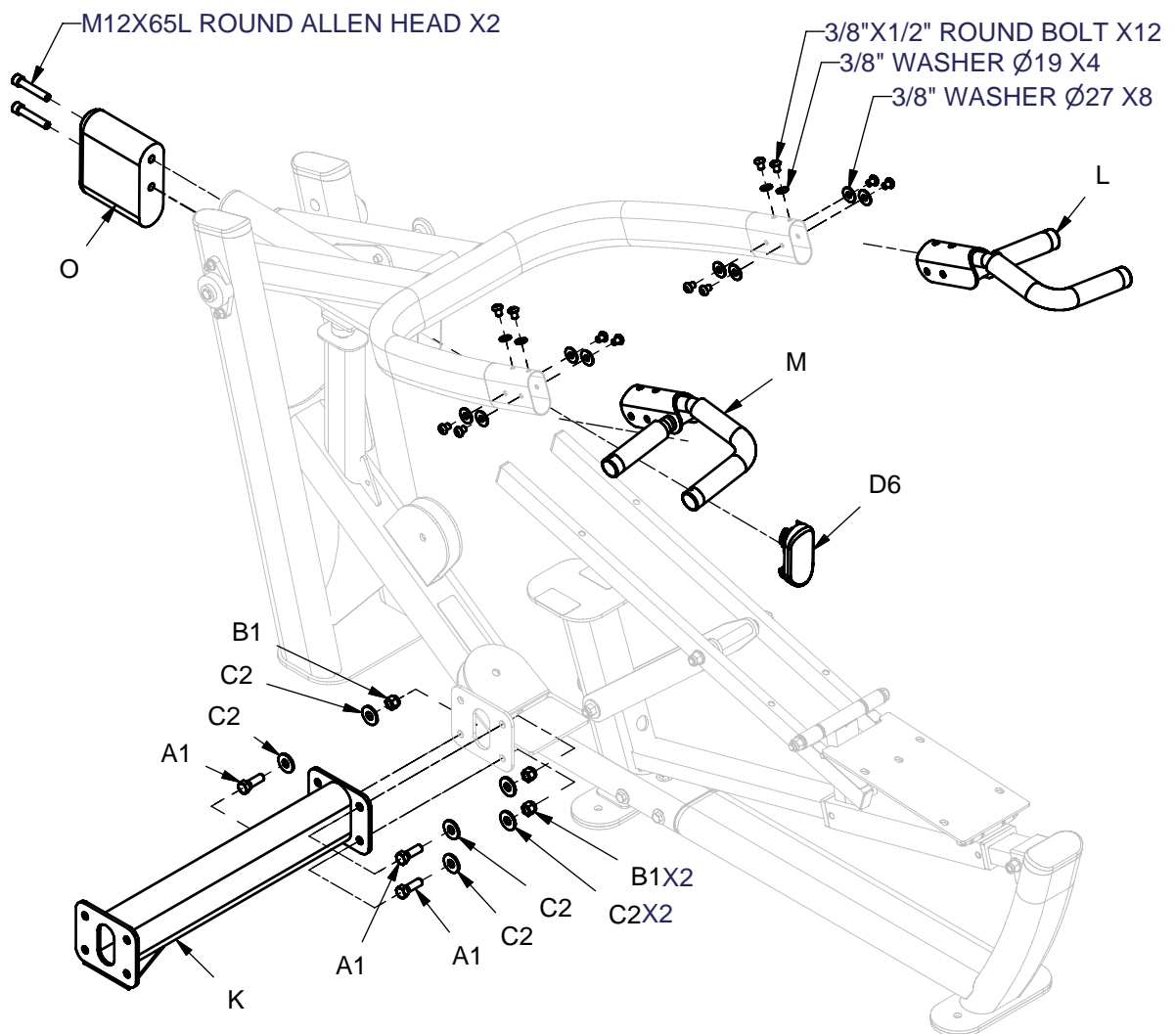

DPRS ASSEMBLY INSTRUCTIONS

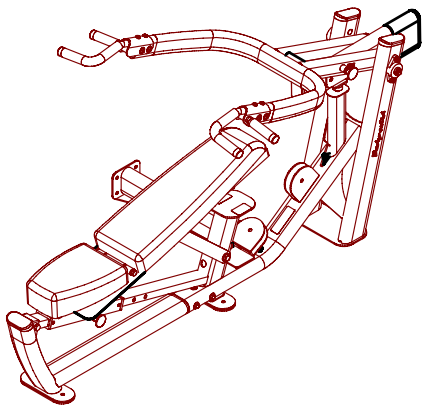

Above shows STEP 6
assembled and completed

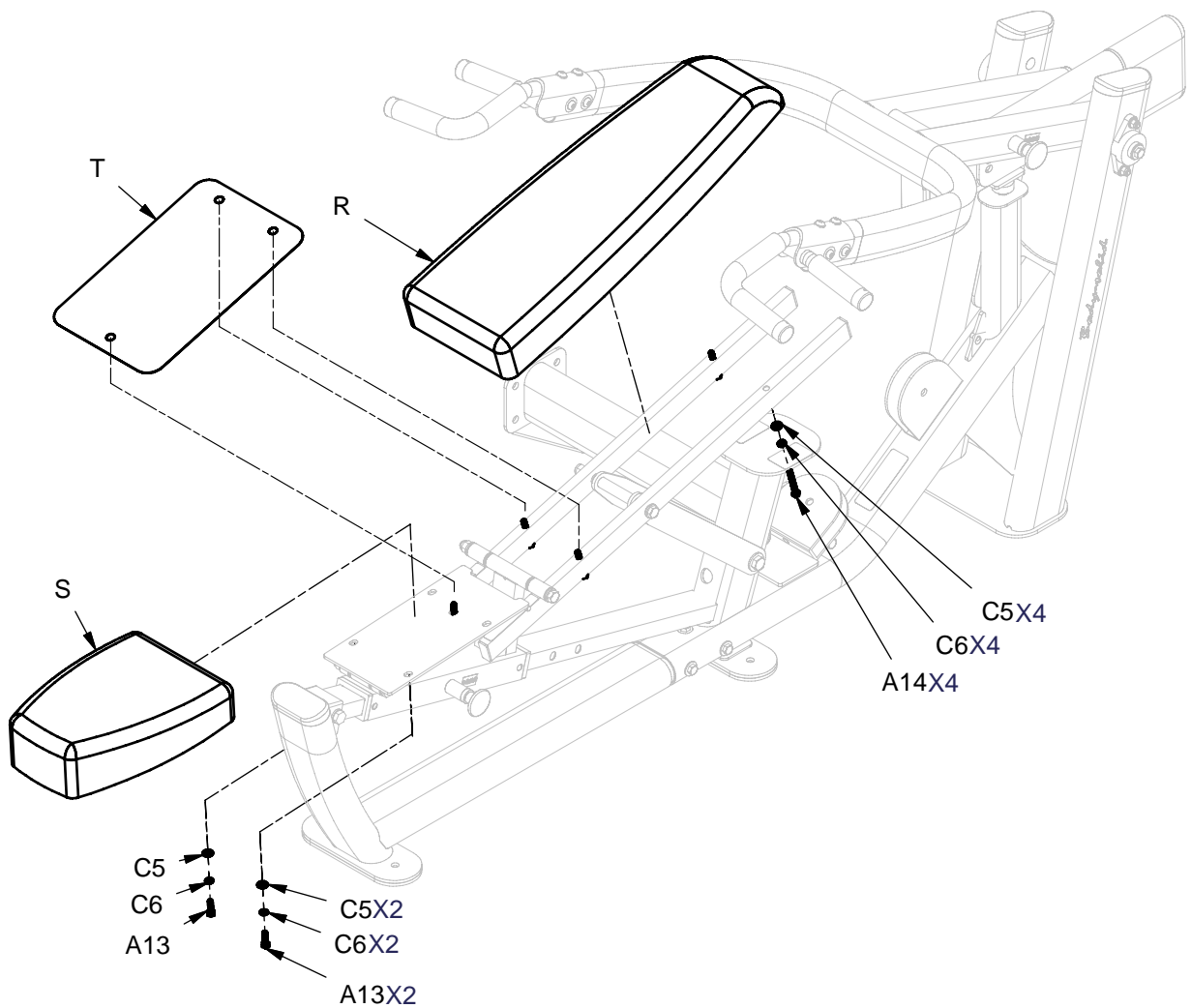

DPRS ASSEMBLY INSTRUCTIONS

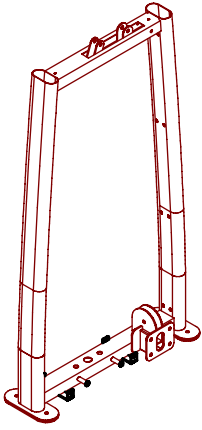

Above shows STEP 7
assembled and completed

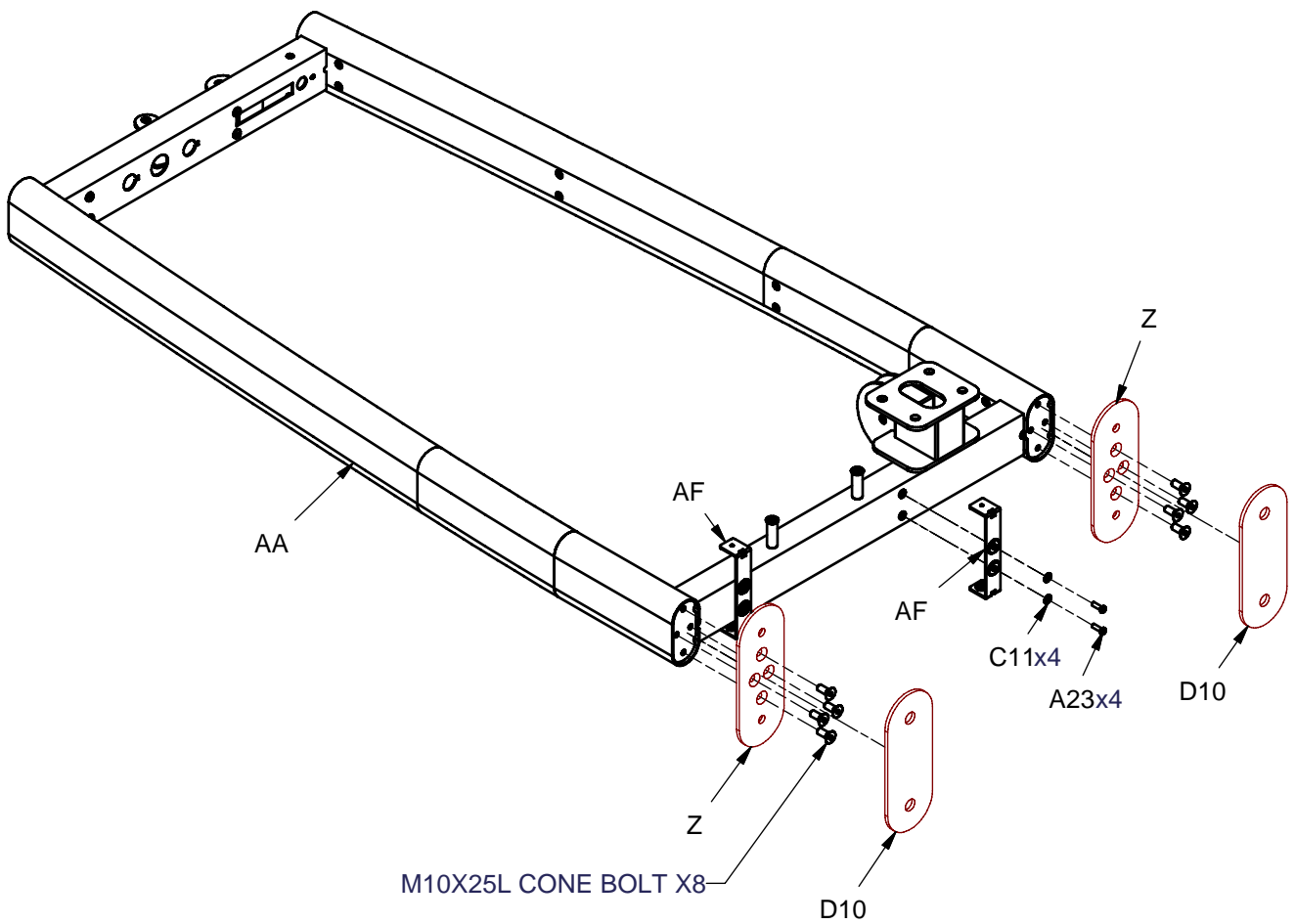

DPRS ASSEMBLY INSTRUCTIONS

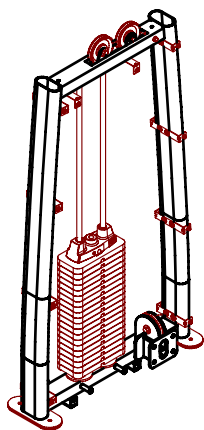

Above shows STEP 8 assembled and completed

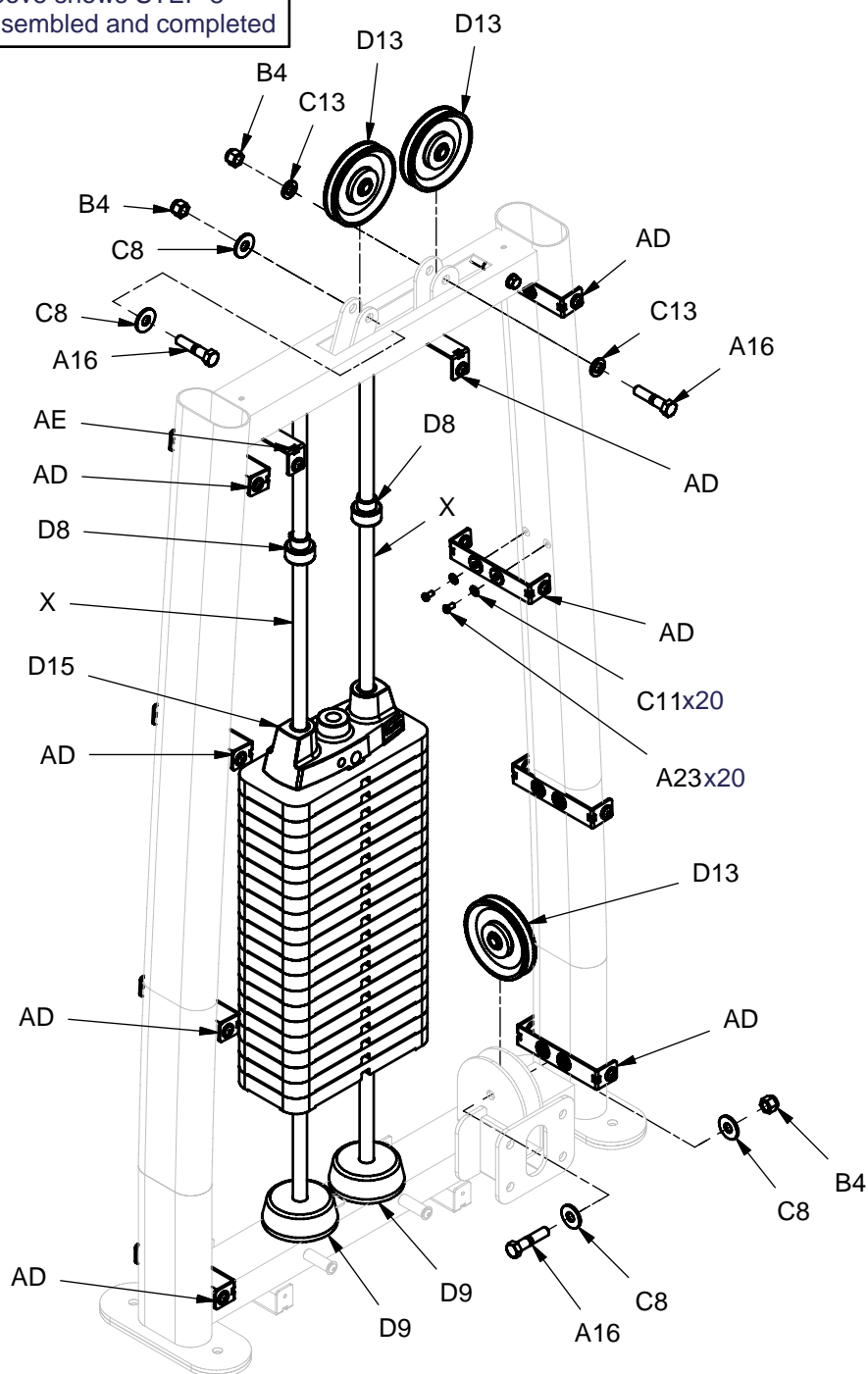

DPRS ASSEMBLY INSTRUCTIONS

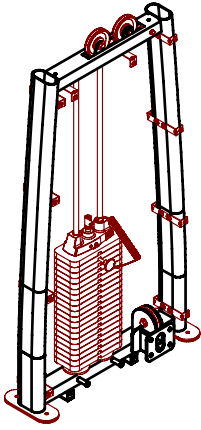

Above shows STEP 9
assembled and completed

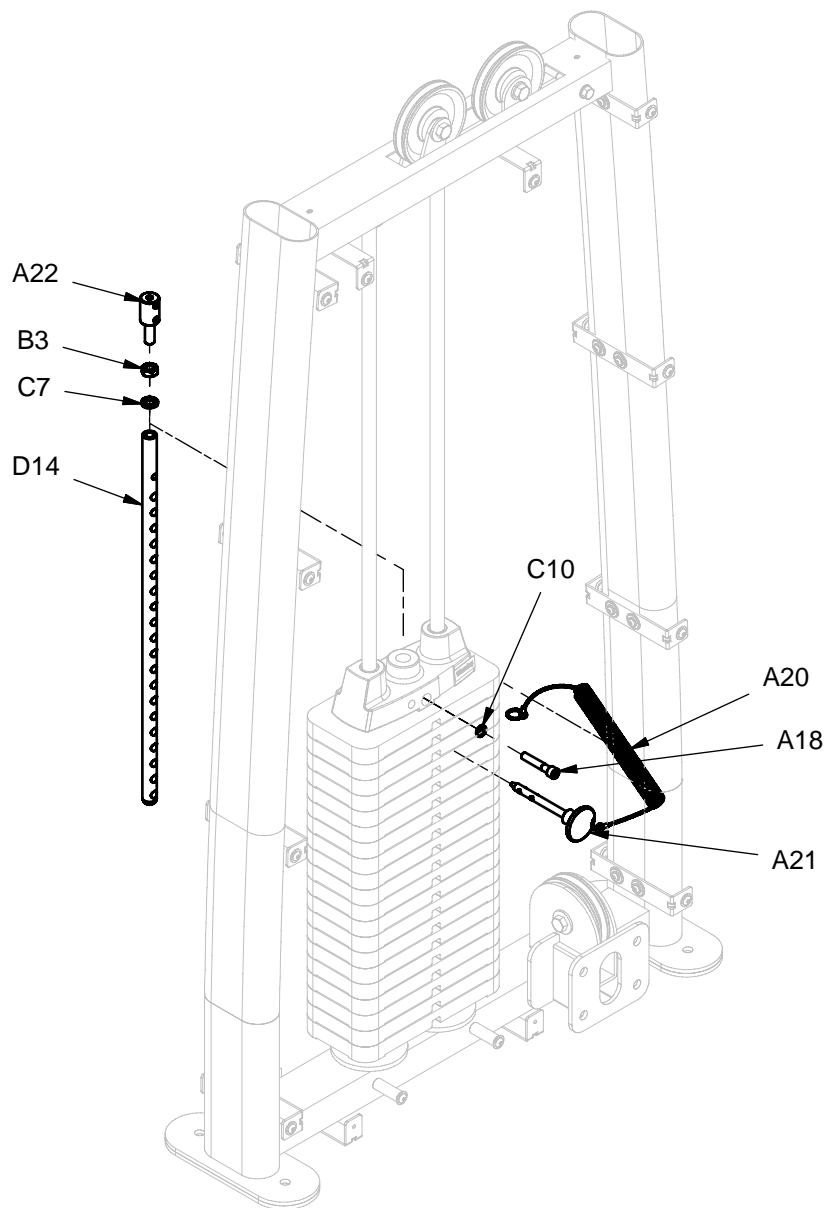

DPRS ASSEMBLY INSTRUCTIONS

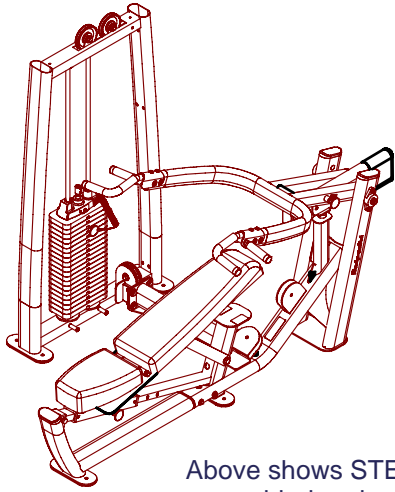

Above shows STEP 10
assembled and completed

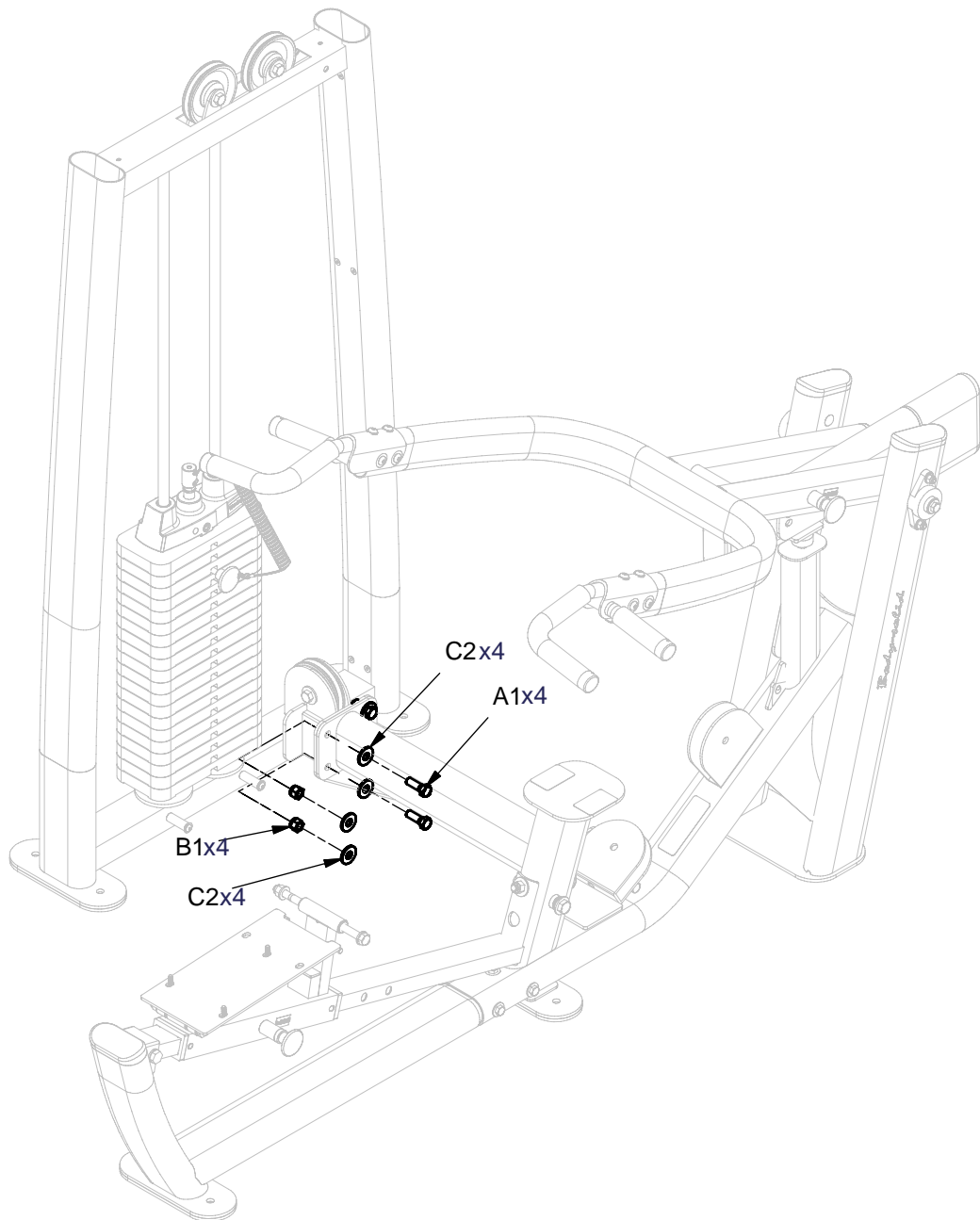

DPRS ASSEMBLY INSTRUCTIONS

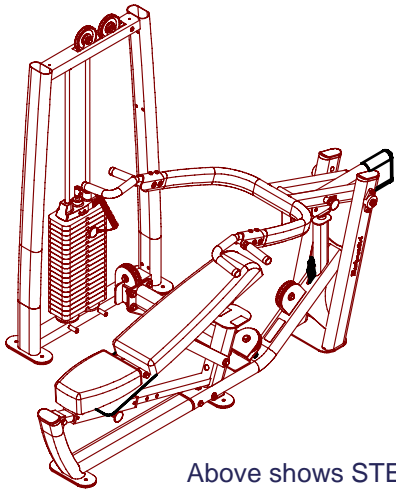

Above shows STEP 11
assembled and completed

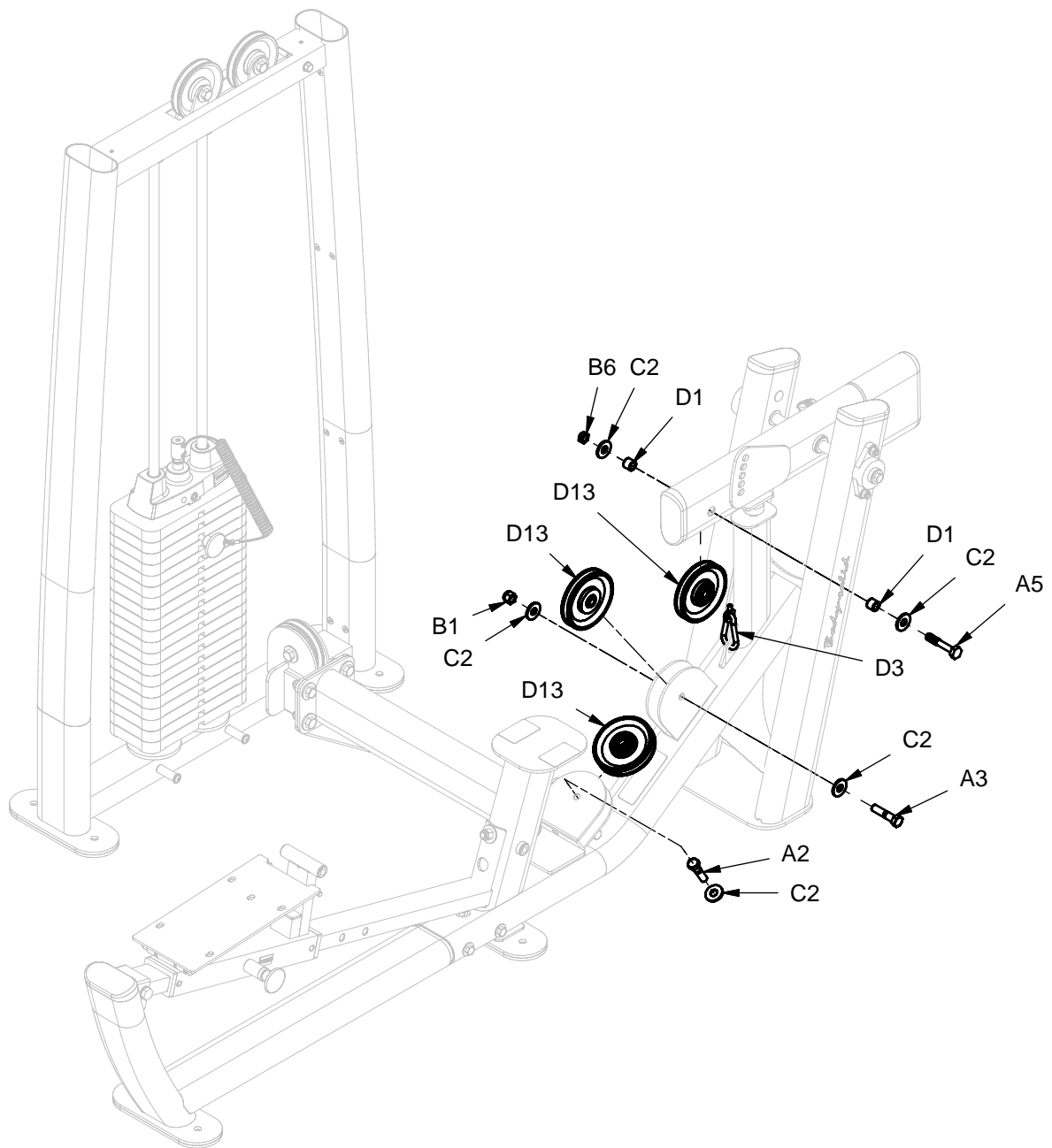

DPRS ASSEMBLY INSTRUCTIONS

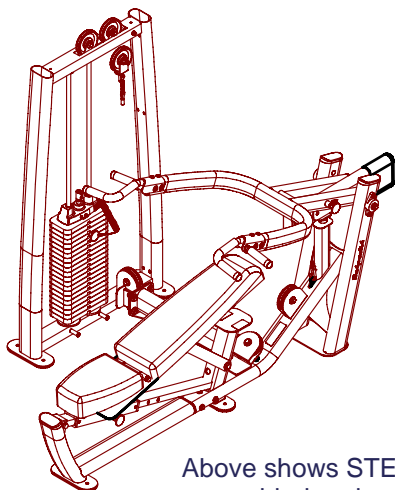

Above shows STEP 12 assembled and completed

Cable to match illustration

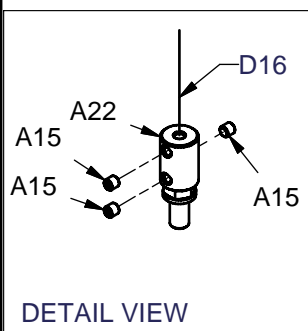
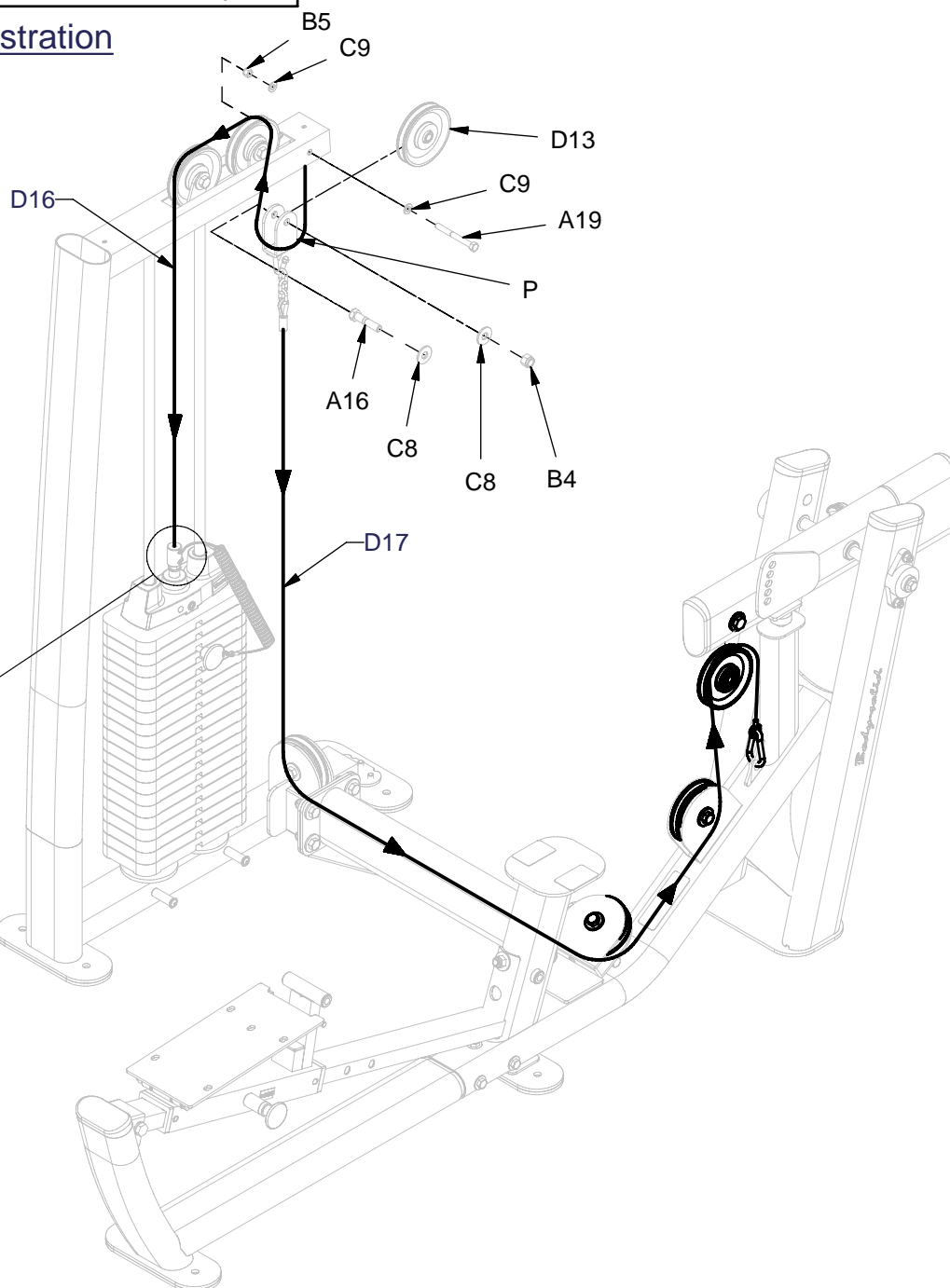

DPRS ASSEMBLY INSTRUCTIONS

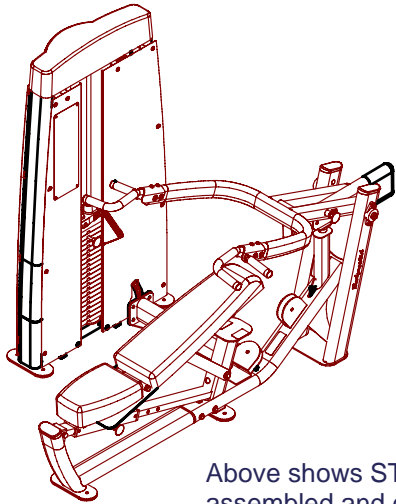

Above shows STEP 12
assembled and completed

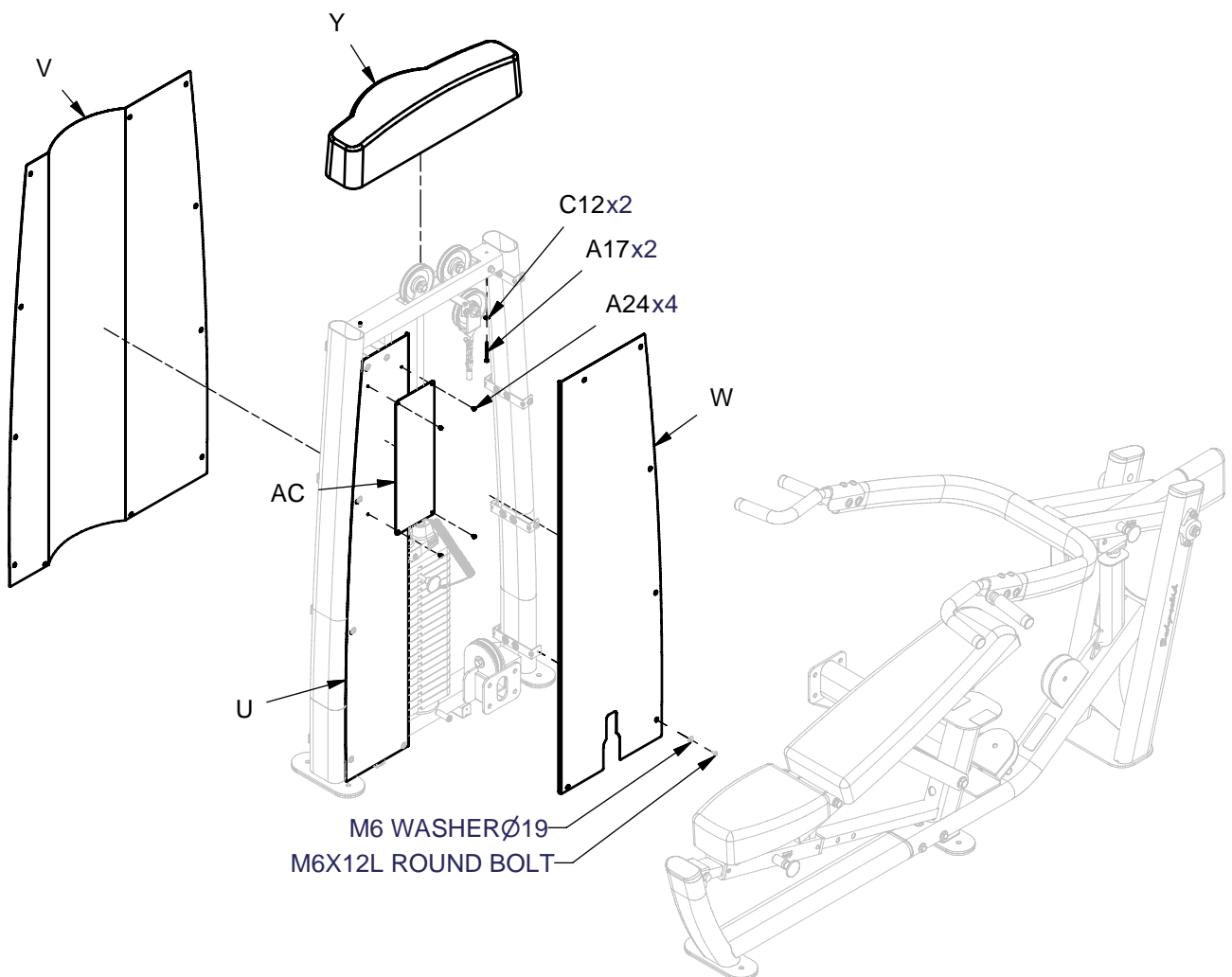

DPRS ASSEMBLY INSTRUCTIONS

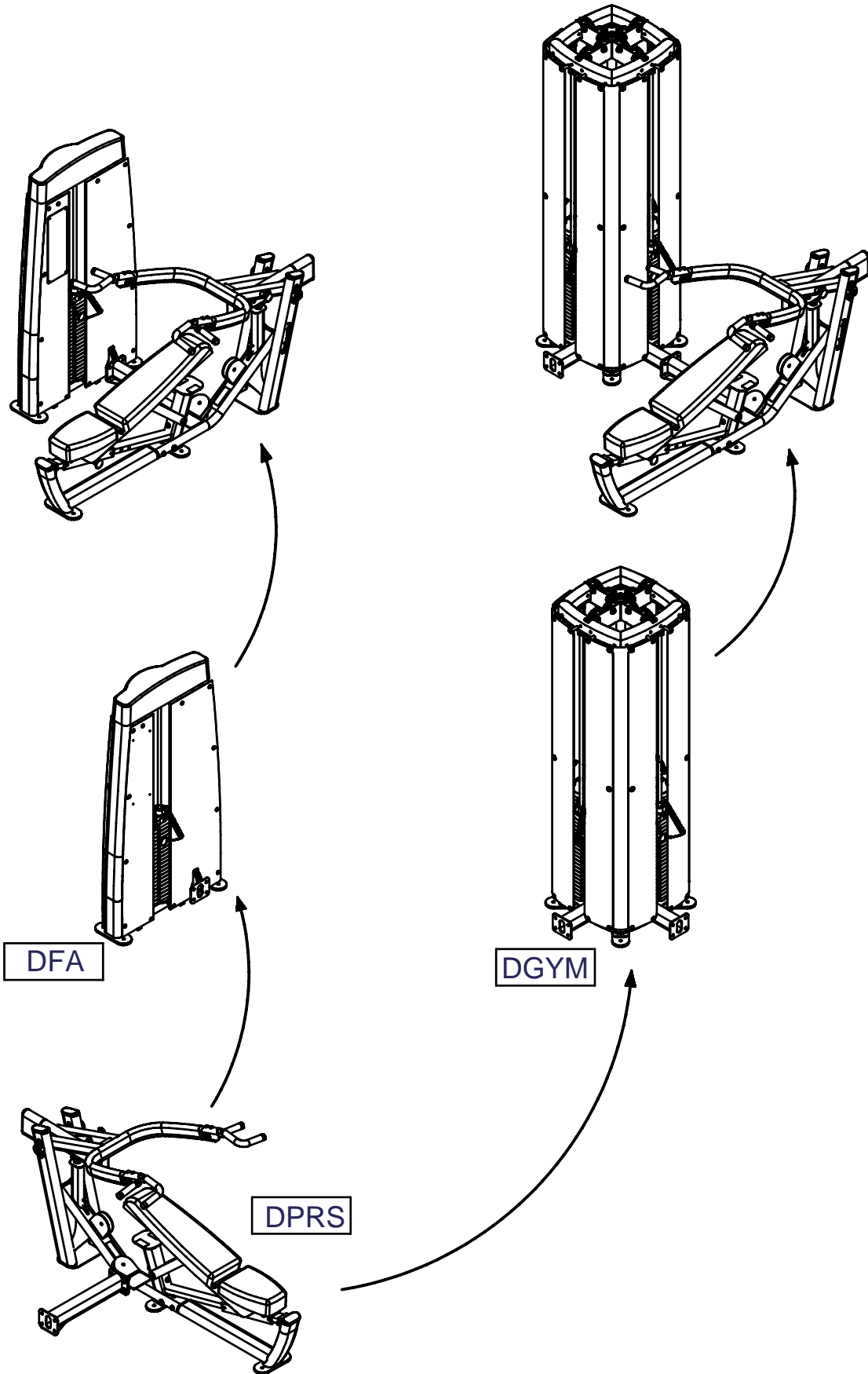

DPRS ASSEMBLY INSTRUCTIONS

Cable to match illustration

