

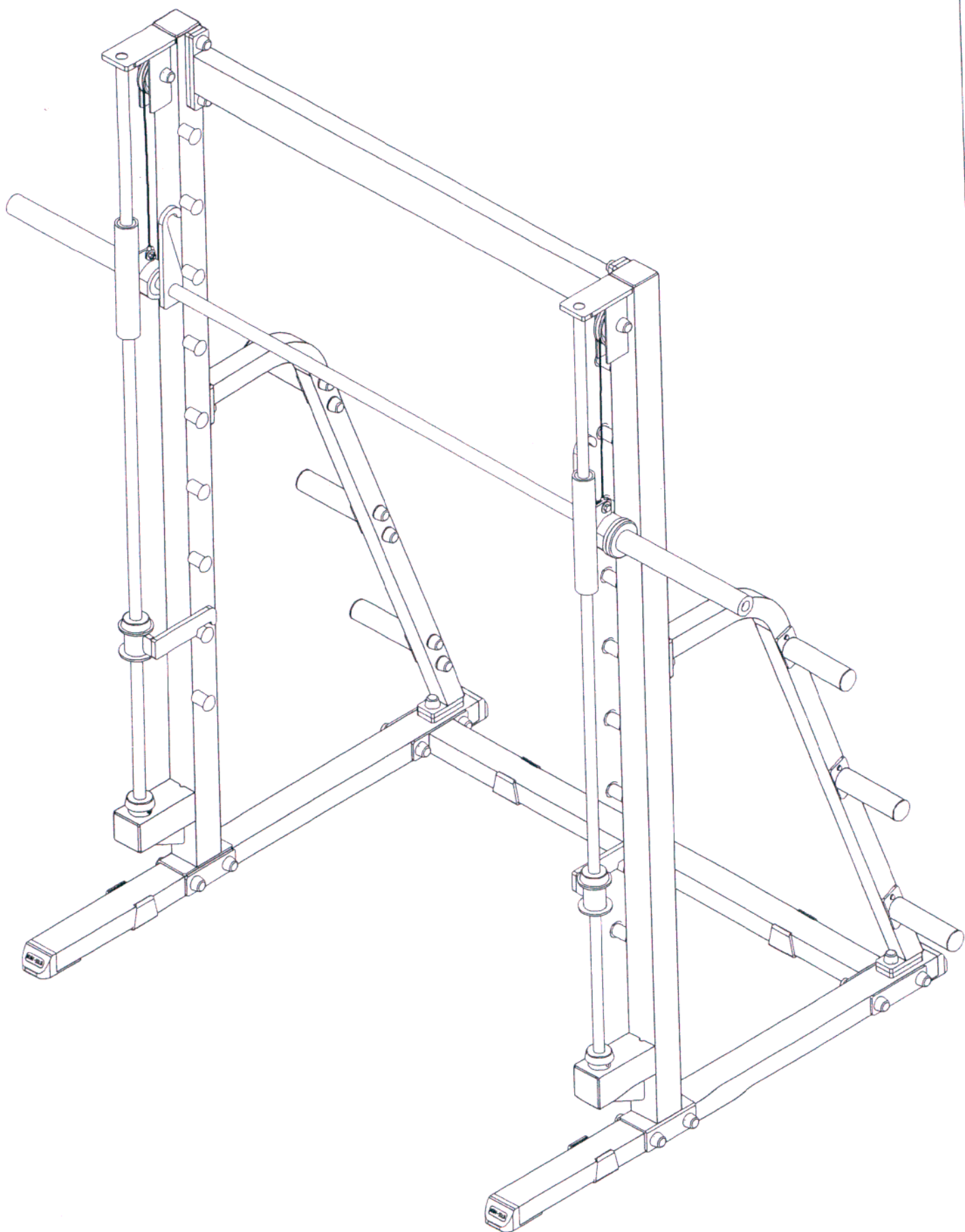











SSM-350.1



VERSION 0009

SSM-350.1 HARDWARE ILLUSTRATION SHEET

	Qty.		Qty.
	A1. 1/2"X4" HEX HEAD BOLT	----	[8PCS]
	A2. 1/2"X2 1/2" HEX HEAD BOLT	----	[12PCS]
	A3. 1/2"X2" HEX HEAD BOLT	----	[2PCS]
	A4. 1/2"X1" HEX HEAD BOLT	----	[8PCS]
	A5. 3/8"X1" HEX HEAD BOLT	----	[2PCS]
	B1. 1/2" NYLON LOCK NUT	----	[10PCS]
	B2. 3/8" NYLON LOCK NUT	----	[2PCS]
	C1. 1/2" ROUND END CAP WASHER	----	[40PCS]
	C2. 1/2" (I.D)WASHER	----	[12PCS]
	C3. 3/8" (I.D)WASHER	----	[4PCS]
	C4. 1/2" SPRING WASHER	----	[8PCS]
	D1. 1/2" BOLT CAP	----	[40PCS]
	D2. ø2 1/2"X19t RUBBER DOUNT(9310-012)	----	[4PCS]
	D3. ø90X10t RUBBER DOUNT (9310-016)	----	[4PCS]
	D4. ø3/4" RUBBER DOUNT (9212-006)	----	[18PCS]
	D5. ø50 ROUND END CAP (9211-020)	----	[6PCS]
	D6. ø4 1/2 " PULLEY (9213-010)	----	[2PCS]
	D7. 75X75 END CAP (9211-007)	----	[4PCS]
	D8. 50X75 FOOT CAP (9211-026)	----	[4PCS]
	D9. 2"X3" RUBBER DOUNT (9212-011)	----	[4PCS]
	D10. 2020mm STEEL CABLE	----	[2PCS]

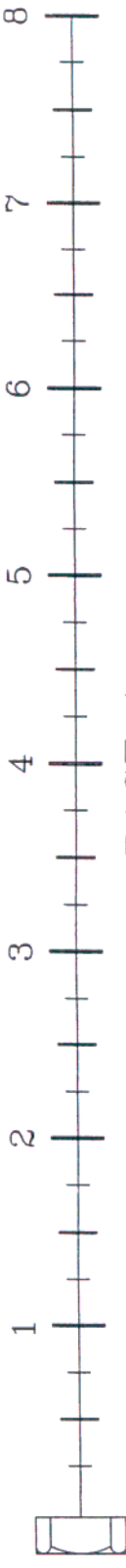
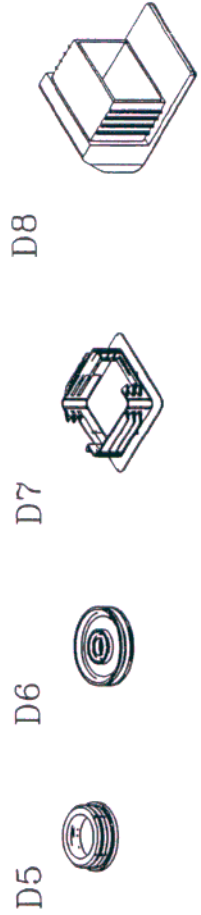

SSM-350.1 PARTS ILLUSTRATION SHEET

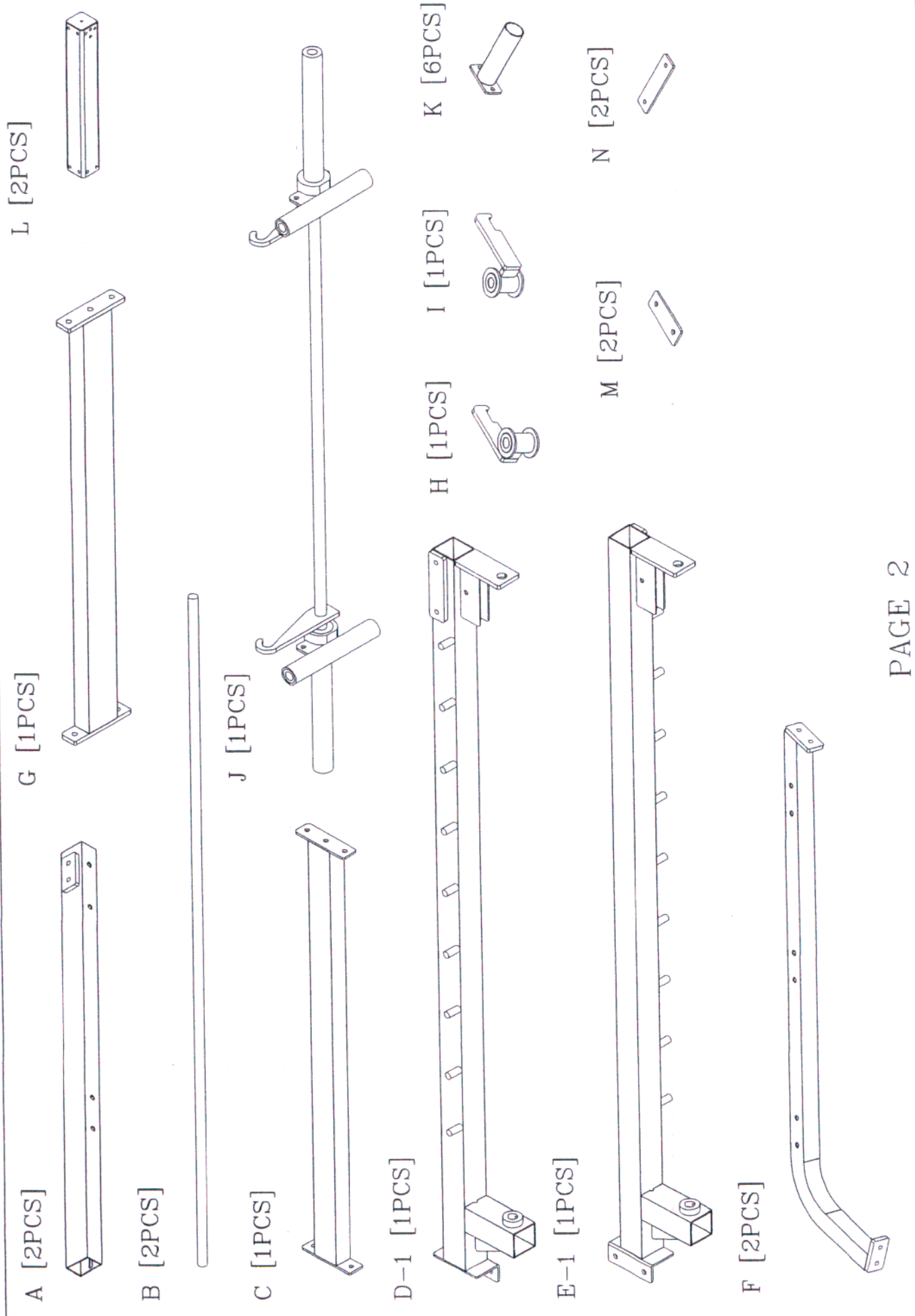

SSM-350.1

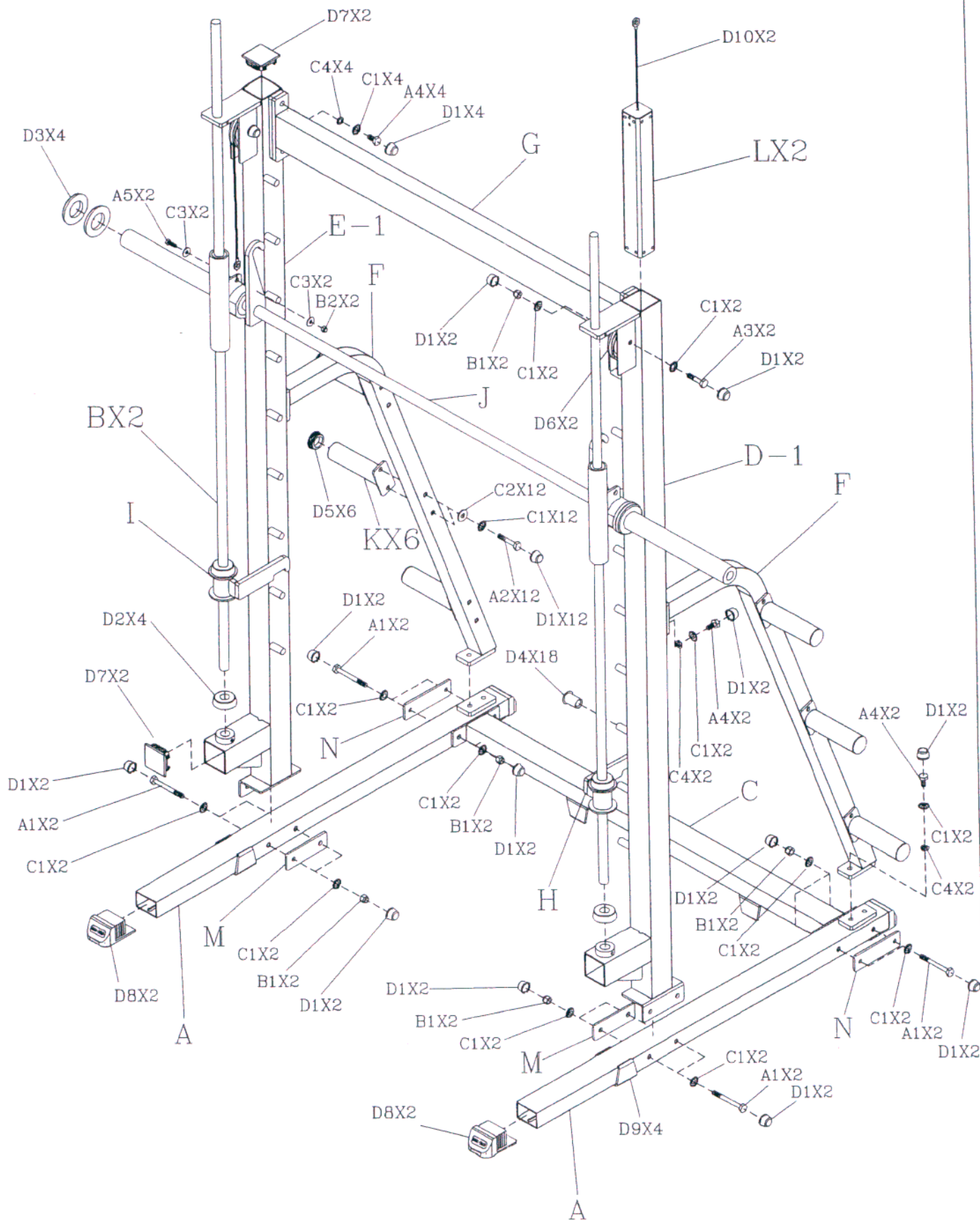

SSM-350.1

While assembling the smith machine it is very important , that while placing the linear bearing covering the on rod (B). You do so as straight as possible. Failing to do so may cause damage to the linear bearings.

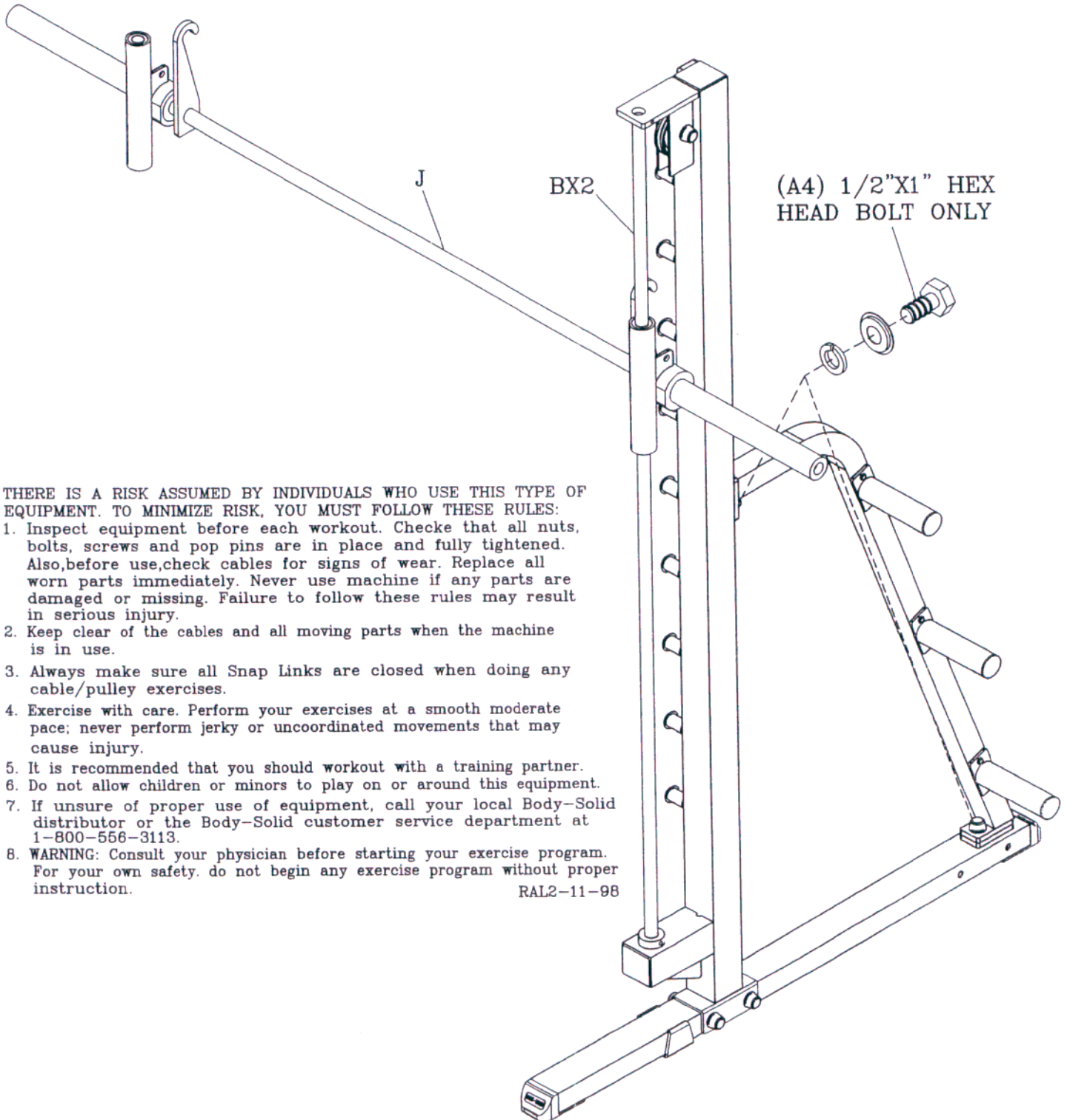

THERE IS A RISK ASSUMED BY INDIVIDUALS WHO USE THIS TYPE OF EQUIPMENT. TO MINIMIZE RISK, YOU MUST FOLLOW THESE RULES:

1. Inspect equipment before each workout. Check that all nuts, bolts, screws and pop pins are in place and fully tightened. Also, before use, check cables for signs of wear. Replace all worn parts immediately. Never use machine if any parts are damaged or missing. Failure to follow these rules may result in serious injury.
2. Keep clear of the cables and all moving parts when the machine is in use.
3. Always make sure all Snap Links are closed when doing any cable/pulley exercises.
4. Exercise with care. Perform your exercises at a smooth moderate pace; never perform jerky or uncoordinated movements that may cause injury.
5. It is recommended that you should workout with a training partner.
6. Do not allow children or minors to play on or around this equipment.
7. If unsure of proper use of equipment, call your local Body-Solid distributor or the Body-Solid customer service department at 1-800-556-3113.
8. **WARNING:** Consult your physician before starting your exercise program. For your own safety, do not begin any exercise program without proper instruction.

RAL2-11-98

Warning

Safety and Maintenance of Cables

Serious injury can occur if you are struck by falling weights or moving parts. The risk that you assume by using this type of equipment can be reduced by following a few simple steps:

Cable inspection should be performed daily. Inspect all cables, the nylon coating on all cables and the area near the fitting at each end of each cable. **Replace any damaged or worn cables immediately.** Do not allow the machine to be used until damaged or worn cables are replaced.

Important: Cables are wear items. It is your responsibility to prevent unexpected breakage. The actual wire strands, the fittings and the nylon coating itself must all be scrutinized. Using or allowing a machine to be used with a suspect cable can result in serious injury.

The nylon coating on a cable is essential for cable life and safety. Visually inspect all cables and pulleys. Look at the cables as they travel around the cams and pulleys. A cable that is wearing will exhibit a "ballooned" or broken coating in the area that passes over the pulley. Damage to the coating is an early warning signal. A cable should be replaced if the nylon coating is missing, is damaged in any way, has pulled or shrunk from the fittings at the end of the cables, or if it is discolored. Discoloration of the cable coating is an early indication of internal problems such as wear or fraying.

Annual cable replacement (semiannual in multi-user settings) is strongly recommended as an additional precaution. The rate at which cables wear depends on many factors including: number of users, number of repetitions, weight setting, misuse, abuse, etc. Because of this, periodic cable replacement is not a sufficient safeguard against unexpected breakage.

Nothing short of a thorough, careful, daily inspection constitutes an adequate safety program.

Body-Solid, Inc. 1/5/04

WARNING

Safety and Maintenance of Cables

IMPORTANT: Cables are wear items. It is your responsibility to prevent unexpected breakage. **Cable inspection should be performed daily.** Inspect all cables, the nylon coating on all cables, and the area near the fitting at each end of each cable. **Replace any damaged or worn cable immediately.** Do not allow the machine to be used until damaged or worn cables are replaced. Using or allowing a machine to be used with a suspect cable can result in serious injury. See Owner's Manual for more information.

For Body-Solid Customer Service
Call 1-800-556-3113

THERE IS A RISK ASSUMED BY INDIVIDUALS WHO USE THIS TYPE OF EQUIPMENT. TO MINIMIZE RISK, YOU MUST FOLLOW THESE RULES:

1. Inspect equipment before each workout. Check that all nuts, bolts, screws and pop pins are in place and fully tightened. Also, before use, check cables for signs of wear. Replace all worn parts. Immediately. Never use machine if any parts are damaged or missing. Failure to follow these rules may result in serious injury.
2. Keep clear of the cables and all moving parts when the machine is in use.
3. Always make sure all Snap Links are closed when doing any cable/pulley exercises.
4. Exercise with care. Perform your exercises at a smooth moderate pace; never perform jerky or uncoordinated movements that may cause injury.
5. It is recommended that you should workout with a training partner.
6. Do not allow children or minors to play on or around this equipment.
7. If unsure of proper use of equipment, call your local Body-Solid distributor or the Body-Solid customer service department at 1-800-556-3113.
8. **WARNING:** Consult your physician before starting your exercise program. For your own safety, do not begin any exercise program without proper instruction.

FAL2-11-96

BODY-SOLID

COMMERCIAL LIMITED LIFETIME WARRANTY

All users should consult their physician before using this product.

This Limited Lifetime Warranty applies only in the United States to products manufactured and distributed by Body-Solid, Inc. (Body-Solid) under the Body-Solid brand name. The warranty period to the original purchaser is (lifetime) on the frame, welds, weight plates and guide rods, (2) years on pulleys, bushings, bearings and hardware and (1) year on cables, upholstery, grips and all other components not mentioned elsewhere in this warranty.

Body-Solid warrants that the Products you have purchased for commercial use from Body-Solid or from an authorized Body-Solid reseller is free from defects in materials or workmanship under normal use during the warranty period. Your sales receipt, showing the date of purchase of the Products, is your proof of the date of purchase. This warranty extends only to you, the original purchaser. It is not transferable to anyone who subsequently purchases the Product from you. It excludes expendable parts. This Warranty becomes VALID ONLY if the Product is assembled / installed according to the instructions / directions included with the Product.

During the warranty period Body-Solid will at no additional charge, repair or replace (at Body-Solid's option) the Product if it becomes defective, malfunctions, or otherwise fails to conform with this Warranty under normal use. In repairing the Product Body-Solid may replace defective parts or, at the option of Body-Solid, serviceable used parts that are equivalent to new parts in performance. All exchanged parts and Products under this warranty will become the property of Body-Solid. Body-Solid reserves the right to exchange manufacturers of any part to cover existing warranty.

To obtain warranty service, you must return the Product to Body-Solid in its original container (or equivalent). You must pre-pay any shipping charges, export taxes, customs duties and taxes, or any other charges with transportation of the Product. In addition, you are responsible for insuring any Products shipped or returned. You assume the risk of loss during shipment. You must present

Body-Solid with proof-of-purchase documents (including the date of purchase). Any evidence of alteration, erasing or forgery of proof-of-purchase documents will be cause to void this warranty.

This warranty does not extend to any Product not purchased from Body-Solid or from an authorized Body-Solid reseller. This Warranty does not extend to any Product that has been damaged or rendered defective; (a) as a result of accident, or abuse; (b) by the use of parts not manufactured or sold by Body-Solid; (c) by modification of the Product; (d) as a result of service by anyone other than Body-Solid or an authorized Body-Solid warranty service provider. Should any Product submitted for Warranty service be found to be ineligible, an estimate of repair cost will be furnished and the repair will be made if requested by you upon Body-Solid's receipt of payment or acceptable arrangement of payment.

EXCEPT AS EXPRESSLY SET FORTH IN THIS WARRANTY BODY-SOLID MAKES NO OTHER WARRANTIES, EXPRESSED OR IMPLIED INCLUDING ANY IMPLIED WARRANTIES OF MERCHANTABILITY AND FITNESS FOR A PARTICULAR PURPOSE. BODY-SOLID EXPRESSLY DISCLAIMS ALL WARRANTIES NOT STATED IN THIS WARRANTY. ANY IMPLIED WARRANTIES THAT MAY BE IMPOSED BY LAW ARE LIMITED TO THE TERMS OF THIS WARRANTY. NEITHER BODY-SOLID NOR ANY OF ITS AFFILIATES SHALL BE RESPONSIBLE FOR INCIDENTAL OR CONSEQUENTIAL DAMAGES. SOME STATES DO NOT ALLOW LIMITATIONS ON HOW LONG AN IMPLIED WARRANTY LASTS OR THE EXCLUSION MAY NOT APPLY TO YOU. This Warranty gives you specific legal rights and you may also have other rights that may vary from state to state. This is the only express warranty applicable to Body-Solid branded products. Body-Solid neither assumes nor authorizes anyone to assume for it any other express warranty.

Common parts orders are normally processed and shipped within 48 hours by UPS or RPS ground service. Parts orders can be shipped by DHL or Fed Ex at customer's request and additional expense.

Before returning a product you must call Body-Solid at 1-800-556-3113 to obtain a Return Authorization Number. No returns will be accepted without the Return Authorization Number. Original purchase must pre-pay all freight charges on warranty claims. Body-Solid will not accept Freight Collect shipments or return shipments on a freight collect basis.

ref. 10/2000

↑ KEEP THIS HALF FOR YOUR RECORDS ↑

COMMERCIAL LIMITED LIFETIME WARRANTY

Congratulations! You have just purchased a quality Body-Solid product. You must fill out this Warranty Registration Card completely, sign it and return it to Body-Solid within 30 days of purchase for this warranty to be valid.

Club, Gym or School Name

Buyer's First Name _____ Buyer's Last Name _____

Street

City _____ State _____ Zip Code _____

Country _____ Phone _____

ITEM NO. _____

ITEM NAME _____

DATE OF PURCHASE _____

CAUTION PLEASE WARNING

THERE IS A RISK ASSUMED BY INDIVIDUALS WHO USE THIS TYPE OF EQUIPMENT. TO MINIMIZE RISK, YOU MUST FOLLOW THESE RULES:

1. Inspect equipment before each workout. Check that all nuts, bolts, screws and pop pins are in place and fully tightened. Also, before use, check cables for signs of wear. Replace all worn parts immediately. Never use machine if any parts are damaged or missing. Failure to follow these rules may result in serious injury.
2. Keep clear of the cables and all moving parts when the machine is in use.
3. Always make sure all Snap Links are closed when doing any cable / pulley exercises.
4. Exercise with care. Perform your exercises at a smooth moderate pace, never perform jerky or uncoordinated movements that may cause injury.
5. It is recommended that you should workout with a training partner.
6. Do not allow children or minors to play on or around this equipment.
7. If unsure of proper use of equipment, call your local Body-Solid distributor or the Body-Solid customer service department at 1-800-556-3113.
8. **WARNING:** Consult your physician before starting your exercise program. For your own safety, do not begin any exercise program without proper instruction.

<p>1. Where did you purchase this product from?</p> <p>_____</p> <p>_____</p>	<p>1. Who will use this product?</p> <p>_____ % Male _____ % Female</p>
<p>2. How did you learn of this product?</p> <p><input type="checkbox"/> TV <input type="checkbox"/> Friend</p> <p><input type="checkbox"/> Radio <input type="checkbox"/> Print Ad / Flyer</p> <p><input type="checkbox"/> In Store Display <input type="checkbox"/> Catalog</p> <p><input type="checkbox"/> Salesperson <input type="checkbox"/> Other _____</p>	<p>2. Why did you choose our product?</p> <p><input type="checkbox"/> Quality <input type="checkbox"/> Brand Name</p> <p><input type="checkbox"/> Features <input type="checkbox"/> Price / Value</p> <p><input type="checkbox"/> Appearance / Style <input type="checkbox"/> Warranty</p> <p><input type="checkbox"/> Design / Function <input type="checkbox"/> Other _____</p>

Please sign: _____



**Commercial Limited
LIFETIME
WARRANTY
Registration
Card**

See Details On Back.

You must complete and return Registration Card
to Body-Solid within 30 days for this Warranty to be valid.

PLACE
STAMP
HERE

FROM:

Facility: _____

Name: _____

Attention: _____

Address: _____

Dept: _____

City: _____

State: _____

Zip Code: _____

BODY-SOLID
1900 S. Des plaines Avenue
Forest Park, IL 60130, USA

IMPORTANT:

Commercial Limited Lifetime Warranty Registration Card