

 **Orbit** *ERGOSKI3.0*

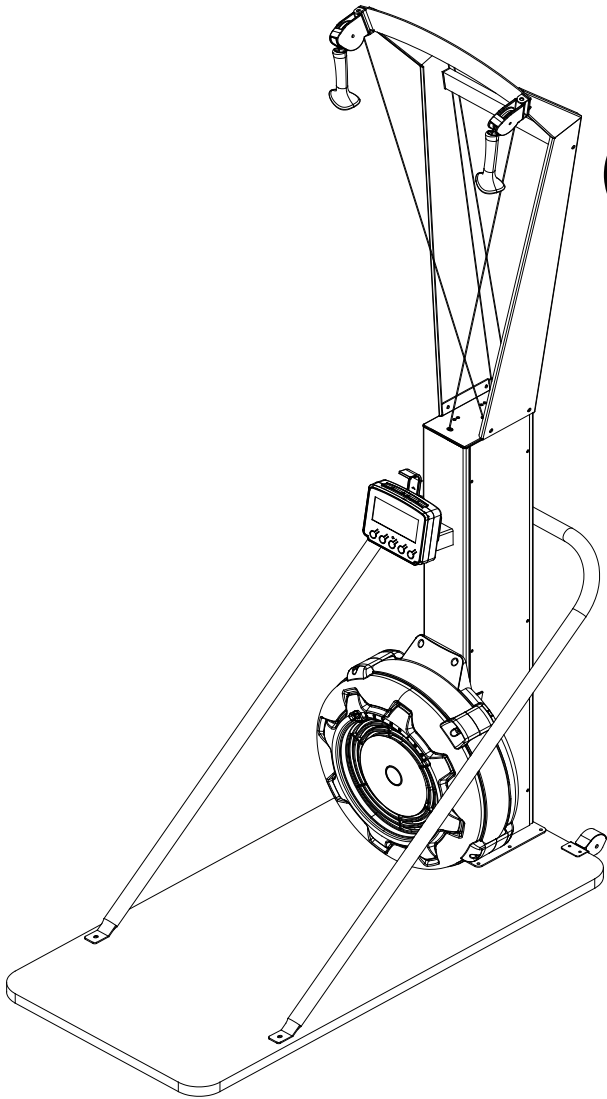

ERGO SKI 3.0 **(Free Standing Style)**

- **Warranty**
- **Assembly**
- **Parts**

**TOOL REQUIRED
FOR ASSEMBLY**
Adjustable Wrench
Pliers
Hammer

Owner's manual ERGO SKI 3.0

CAUTION : 1. *Weight on this product should not exceed 330 lbs/150 kgs.*

2. *Exercise of a strenuous nature, as is customarily done on this equipment, should not be undertaken without first consulting a physician. No specific health claims are made or implied as they relate to the equipment. Measurements made by the equipment are believed to be accurate, but only The measurements of your physician should be relied upon.*

IMPORTANT: *Read all instructions carefully before using this product. Retain this product. Owner's manual for future reference.*

TABLE OF CONTENTS

Safety Instructions	2	Storage	21
Before You Begin	3	Product Parts Drawing	22
Hardware Identification Chart	4	Parts List.....	23
Assembly Instructions	6		
Computer Instructions	14		
Operational Instructions	19		
Maintenance	20		

SAFETY INSTRUCTIONS

1. To reduce the risk of serious injury, read the following Safe Instructions before using the **ERGO SKI 3.0**.
2. Save these instructions and ensure that other exercisers read this manual prior to using the **ERGO SKI 3.0** for the first time.
3. Read all warnings and cautions posted on the **ERGO SKI 3.0**.
4. The **ERGO SKI 3.0** should only be used after a thorough review of the Owner's Manual. Make sure that it is properly assembled and tightened before use.
5. We recommend that two people be available for assembly of this product.
6. Keep children away from the **ERGO SKI 3.0**. Do not allow children to use or play on the **ERGO SKI 3.0**. Keep children and pets away from the **ERGO SKI 3.0** when it is in use.
7. It is recommended that you place this exercise equipment on an equipment mat.
8. Set up and operate the **ERGO SKI 3.0** on a solid level surface. Do not position the **ERGO SKI 3.0** on loose rugs or uneven surfaces.
9. Make sure that adequate space is available for access to and around the **ERGO SKI 3.0**.
10. Before using, inspect the **ERGO SKI 3.0** for worn or loose components, and securely tighten or replace any worn or loose components prior to use.
11. Before using, check the condition of the DRIVE CORD (52). Replace the DRIVE CORD (52) if it is damaged or broken.
12. Consult a physician prior to commencing an exercise program and follow his/her recommendations in developing your fitness program. If at any time during exercise you feel faint, dizzy, or experience pain, stop and consult your physician. Failure to follow all warnings and instructions could result in serious injury or death.
13. Always choose the workout which best fits your physical strength and flexibility level. Know your limits and train within them. Always use common sense when exercising.
14. Do not wear loose or dangling clothing while using the **ERGO SKI 3.0**.
15. Never exercise in bare feet or socks; always wear proper footwear such as running, walking, or cross training shoes that fit well, provide foot support, and feature non-skid rubber soles.
16. Be careful to maintain your balance while using, mounting, dismounting, or assembling the **ERGO SKI 3.0**, loss of balance may result in a fall and bodily injury.
17. Do not use the U-BAR BRACKET (6) to move the **ERGO SKI 3.0**. It may cause danger. When assembling or separating the unit, keep all children away and make sure your hands are clear of any pinch point.
18. The **ERGO SKI 3.0** should be used with training area 24 X 52 X 85 inch (61 X 132 X 215.9 cm).
19. The **ERGO SKI 3.0** should be used by only one person at a time.

BEFORE YOU BEGIN

Thank you for choosing the **ERGO SKI 3.0**. We take great pride in producing this quality product and hope it will provide many hours of quality exercise to make you feel better, look better, and enjoy life to its fullest. It's a proven fact that a regular exercise program can improve your physical and mental health. Too often, our busy lifestyles limit our time and opportunity to exercise. The **ERGO SKI 3.0** provides a convenient and simple method to begin your journey of getting your body in shape and

achieving a happier and healthier lifestyle.

Before reading further, please review the drawing below and familiarize yourself with the parts that are labeled.

Read this manual carefully before using the **ERGO SKI 3.0**.

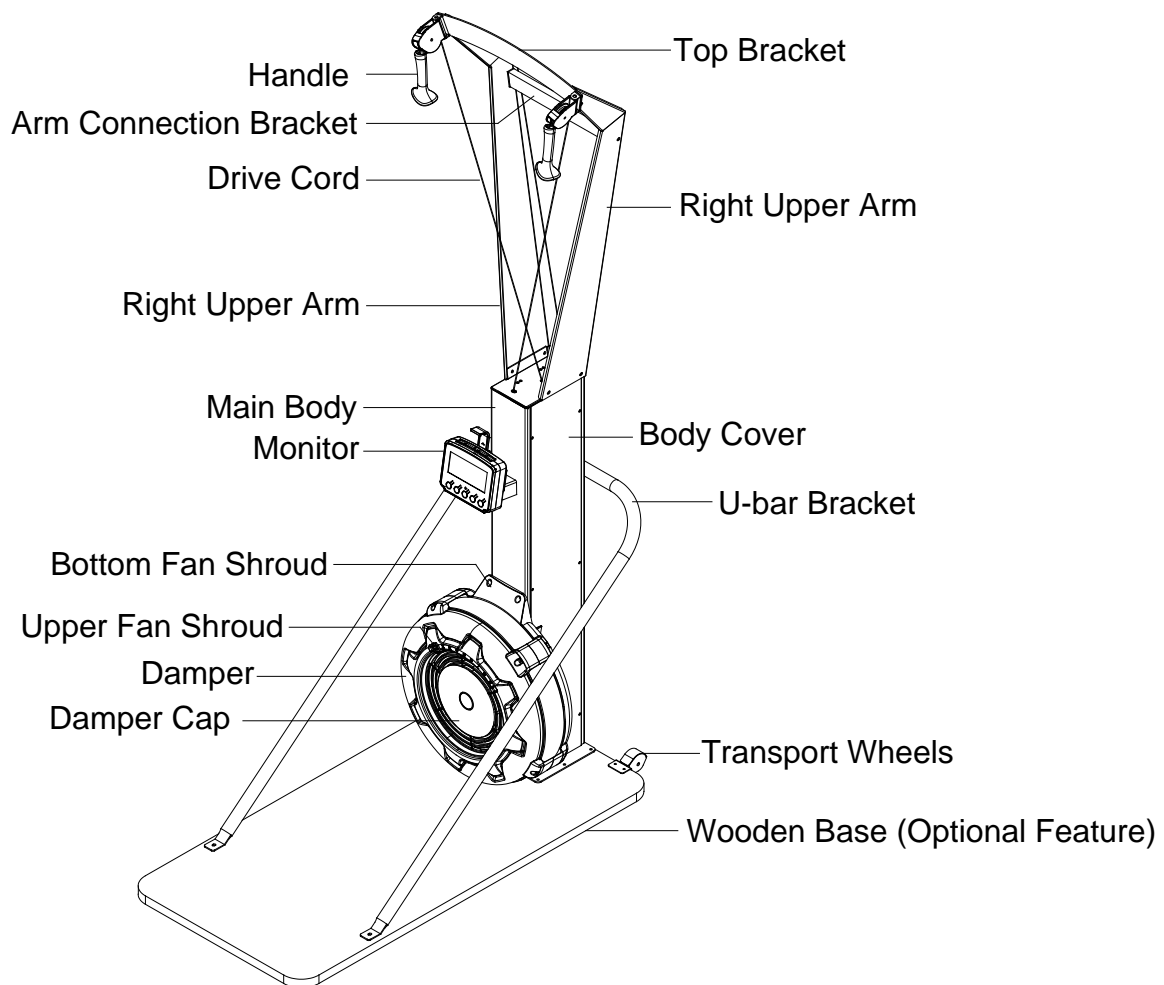

THE FOLLOWING TOOLS ARE INCLUDED FOR ASSEMBLY :



HARDWARE IDENTIFICATION CHART

This chart is provided to help identify the fasteners used in the assembly process. Place the washers or the ends of the bolts or screws on the circles to check for the correct diameter. Use the small scale to check the length of the bolts and screws.

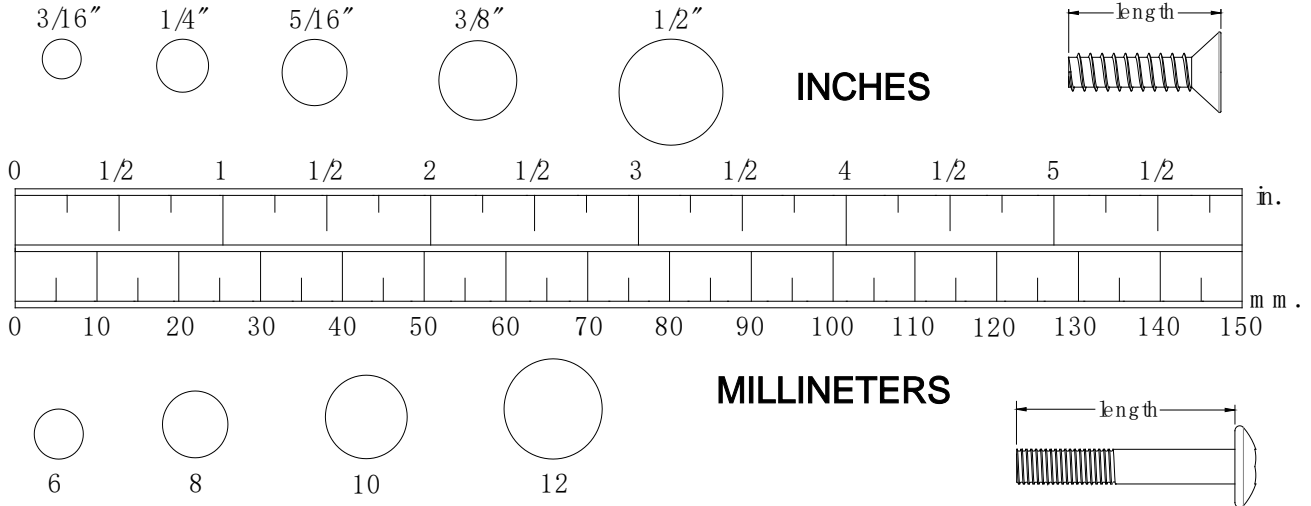

NOTICE: The length of all bolts and screws, except those with flat heads, is measured from below the head to the end of the bolt or screw. Flat head bolts and screws are measured from the top of the head to the end of the bolt or screw.



After unpacking the unit, open the hardware bag and make sure that you have all the following fasteners. Some fasteners may be already attached to the parts.

Below chart include the fasteners for Main Body assembly:



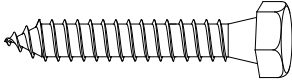
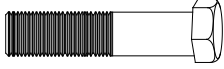

Drawing of Parts	Parts No.	Description	QTY
	#82	Button Head Cap Screw, M8x75 mm	1
	#71	Flat Washer, M8	13
	#72	Nylon Nut, M8	1
	#86 #87	Socket Head Cap Screw, M8x12 mm Socket Head Cap Screw, M8x15 mm	10 2
	#89	Allen Wrench 6mm	1

	#88	Wrench 13-15	1
---	-----	--------------	---

Below chart include the EXTRA fasteners for Wall Mounted Style assembly:

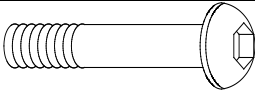
Drawing of Parts	Parts No.	Description	QTY
	#54	Socket Head Cap Screw, ST8x50mm	4
	#53	Socket Head Cap Screw, M8x35 mm	2
	#71	Flat Washer, M8	2
	#55	Flat Washer, $\Phi 22 \times \Phi 9 \times 2.0$ mm	4

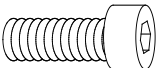
Below chart include the EXTRA fasteners for Fee Standing Style assembly:

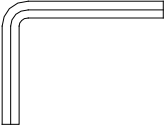
Drawing of Parts	Parts No.	Description	QTY
	#84	Button Head Cap screw, M8x50 mm	2
	#85	Arc washer, M8	2
	#83	Socket Head Cap Screw, M8x30 mm	6
	#71	Flat Washer, M8	6
	#90	Allen Wrench 5mm	1

ASSEMBLY INSTRUCTIONS

STEP 1

Take out **Top Bracket (4)** and place it on the ground right next to Box 1 (called Box A in the drawings), and continue to take out **Main Body (1)**.

NOTE: Fan Shrouds will be easily damaged if it faces down on the ground during the assembly.
NOTE: Do not throw away styrofoams until the assembly is completed.

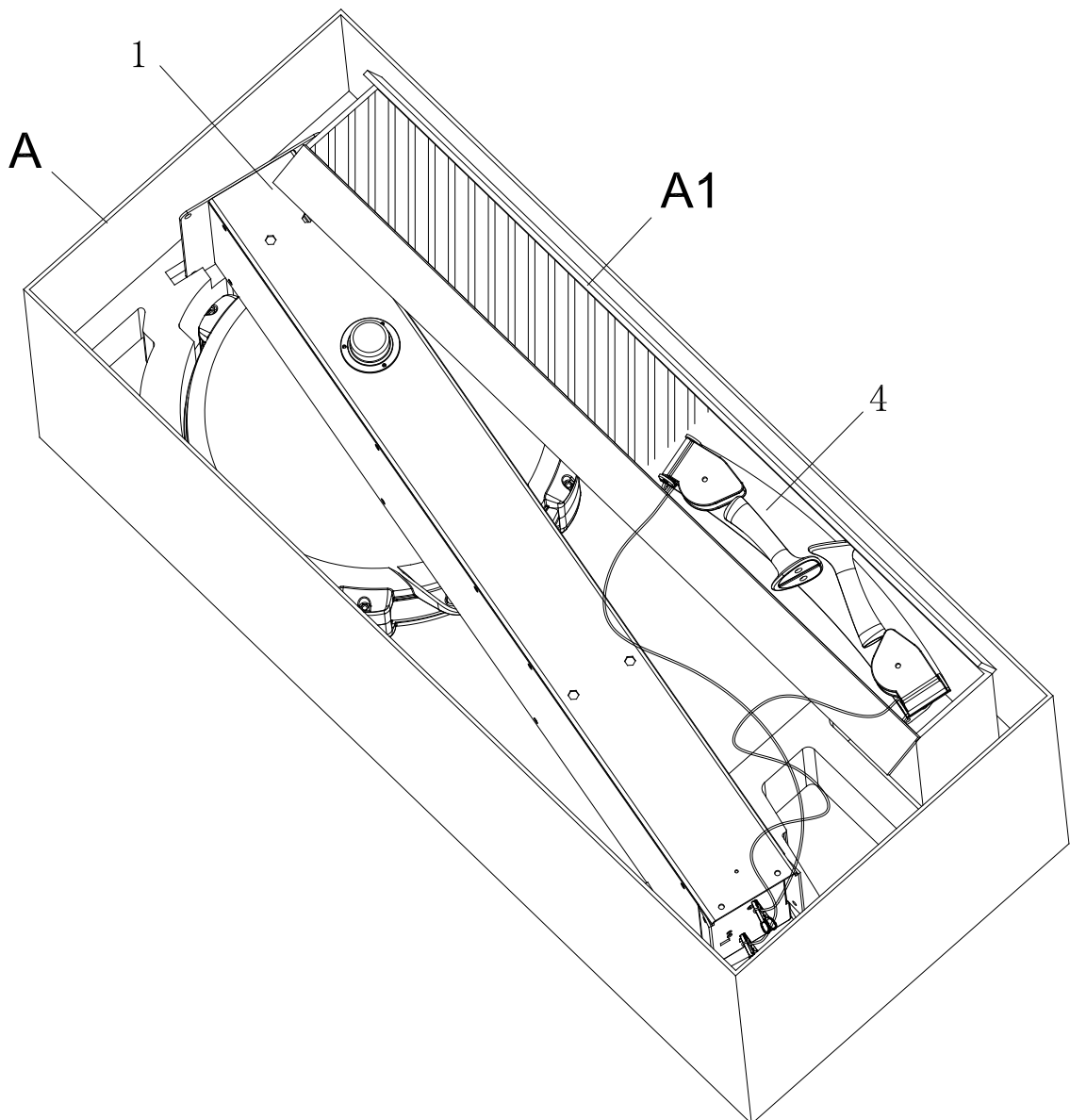

STEP 2

Attach the **Left and Right Upper Arms (2/3)** to **Main Body (1)** to using: 4 PCs of **M8x12mm Socket Head Cap Screw (86)** and **M8 Flat Washer (71)**. Then tighten all bolts.

STEP 3

Attach the **Left and Right Upper Arms (2/3)** to **Arm Connection Bracket (5)** using: 2 PCs of **M8x15mm Socket Head Cap Screw (87)** and **M8 Flat Washer (71)**. Then tighten all bolts.

NOTE: Fully tighten bolts at end of above steps

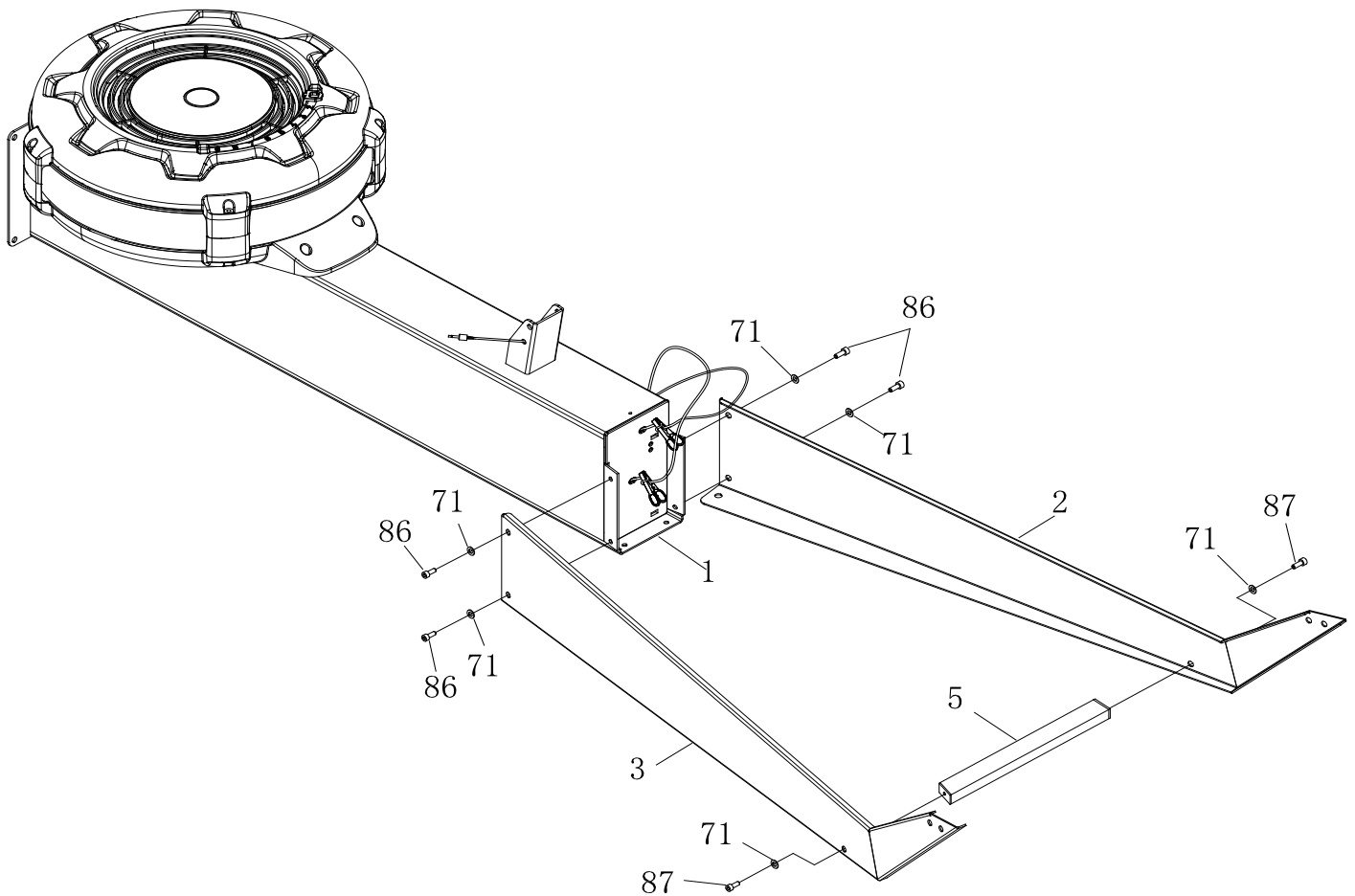
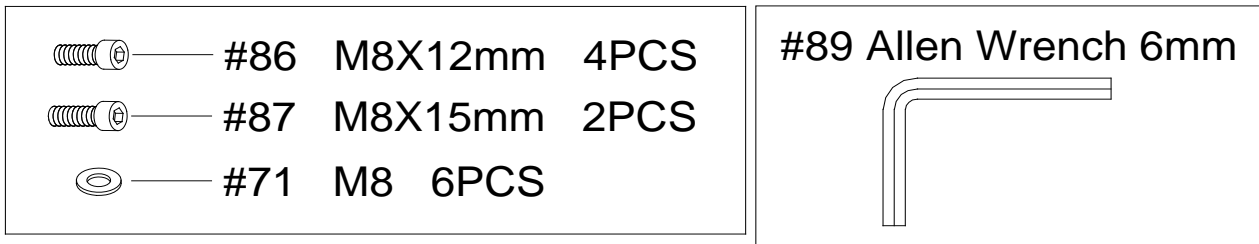

STEP 4

Attach the **Top Bracket (4)** to **Left and Right Upper Arms (2/3)** using: 4 PCs of **M8x12mm Socket Head Cap Screw (86)** and **M8 Flat Washer (71)**. Then tighten all bolts.

NOTE: Fully tighten bolts at end of above step.

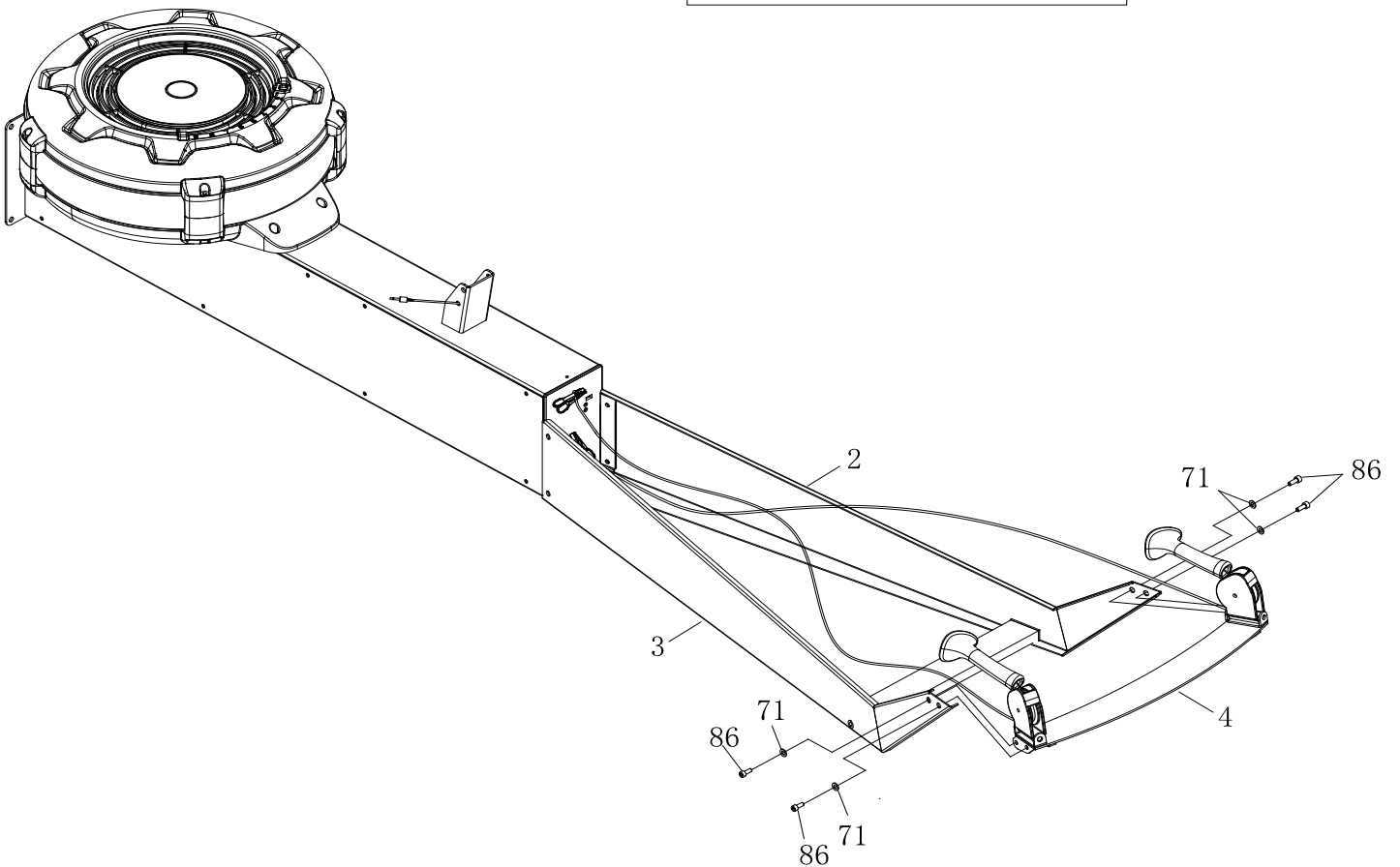
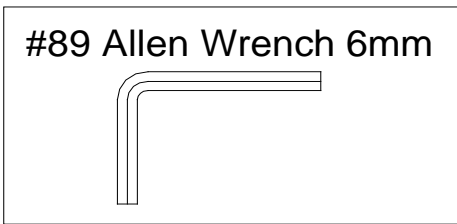
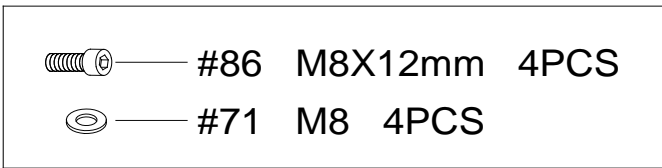

STEP 5

Make the assembly stand up. Tighten the **Left and Right Upper Arms (2/3)** using: 2 PCs of **M8x12mm Socket Head Cap Screw (86)** and **M8 Flat Washer (71)**. Then tighten all bolts.

NOTE: Fully tighten bolts at end of this step.

STEP 6

Remove the clicker from the **Drive Cord (52)**.

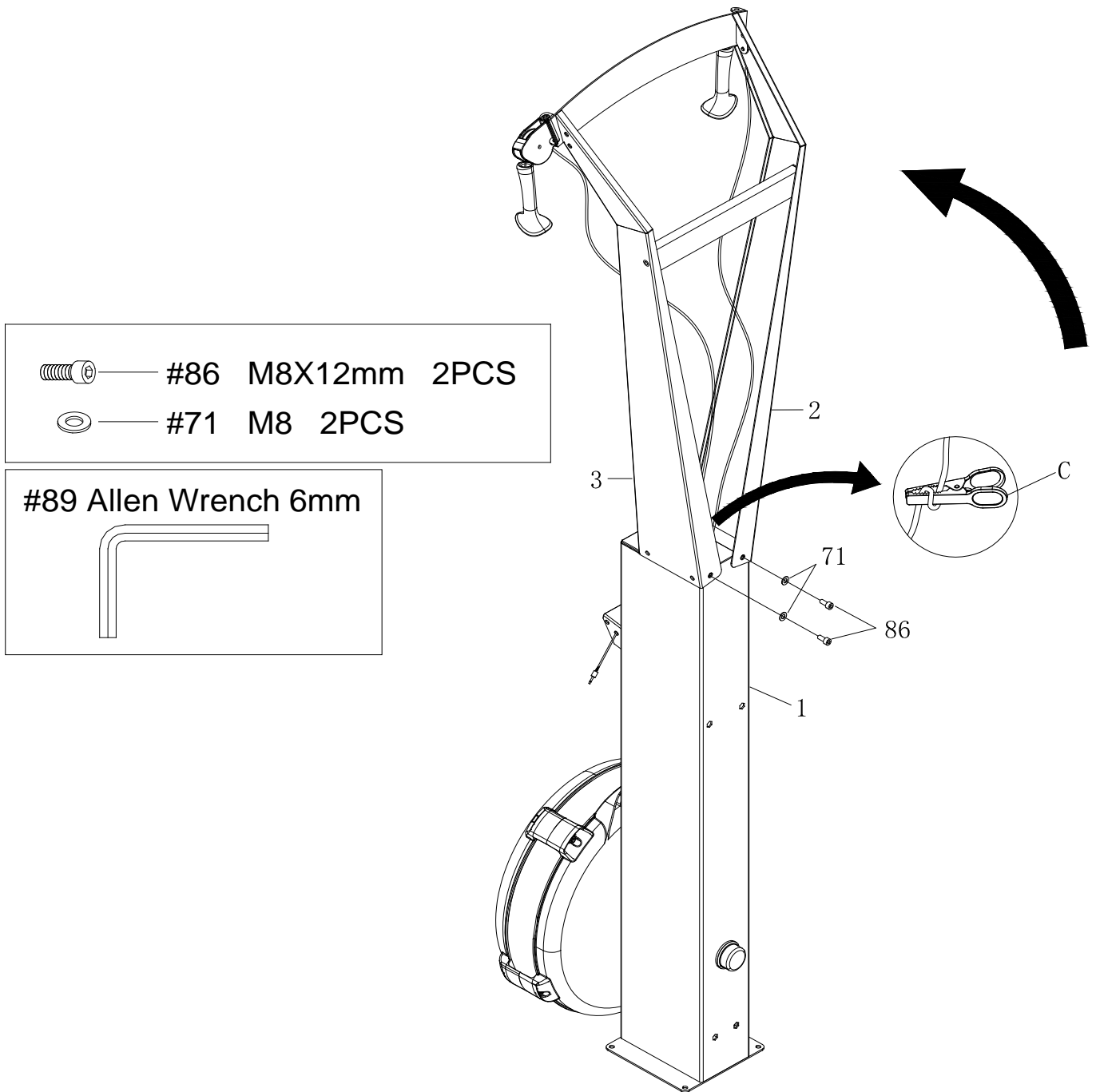

STEP 7

Attach **Cell Phone Bracket (15)** to the **Console Monitor (14)** using **Rubber Band (34)**.

STEP 8

Attach the **Console Monitor (14)** to the console mounting bracket on **Main Body (1)** using: 1 PC of **M8x75mm Button Head Cap Screw (82)**, **M8 Flat Washer (71)**, and **M8 Nylon Nut (72)**.

STEP 9

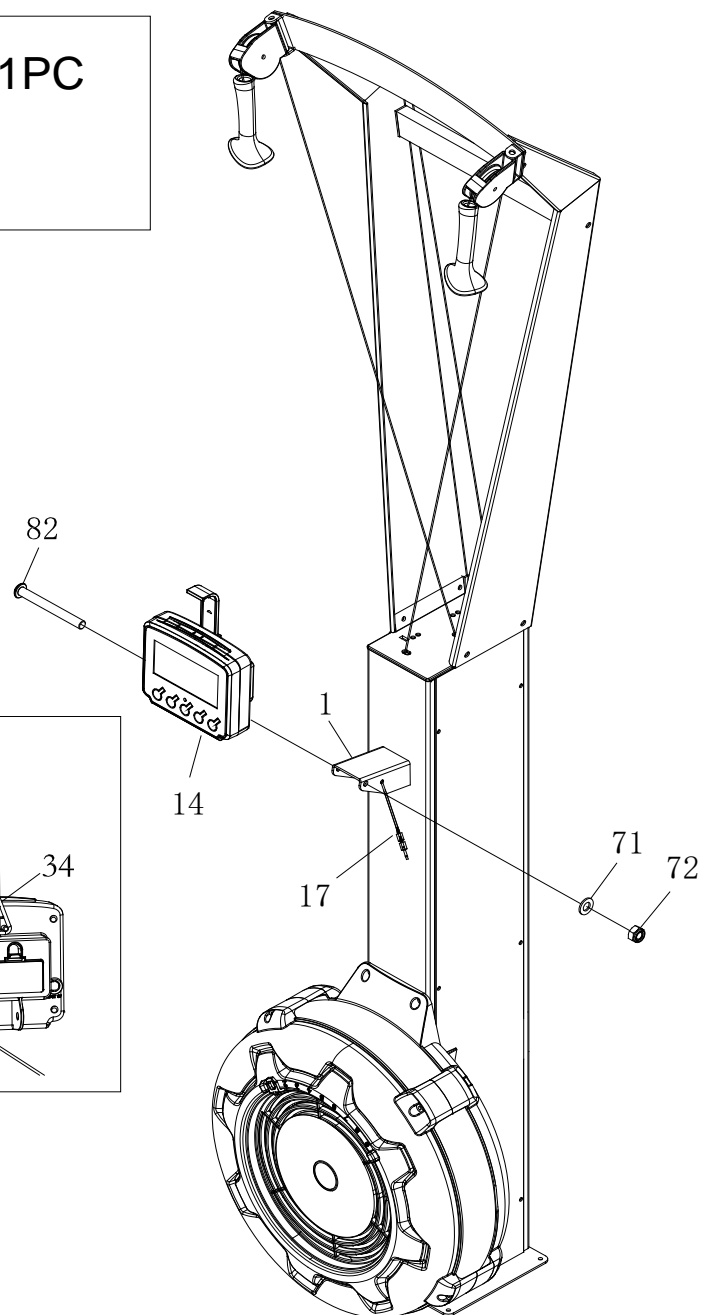
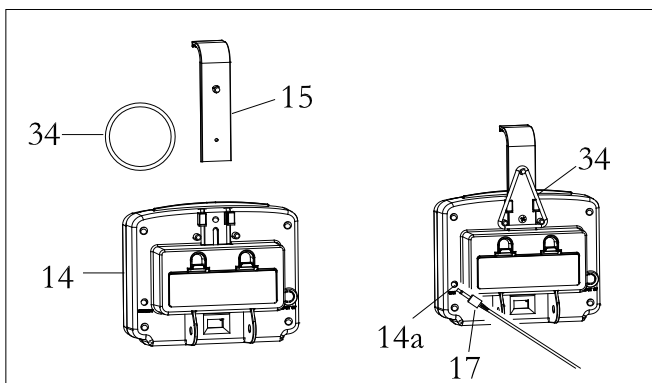
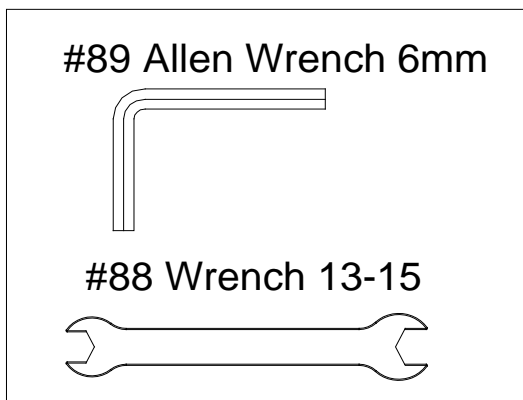
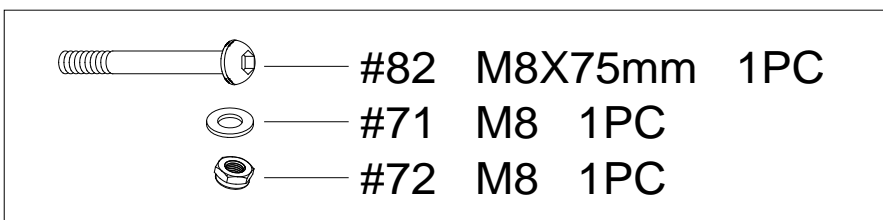

Connect **Sensor Cable (17)** into the back of the **Console Monitor (14a)**.



STEP 10

Attach the **Main Body (1)** to **Wooden Base (18)** using: 4 PCs of **M8x30mm Socket Head Screw (83)** and **M8 Flat Washer (71)**.

NOTE: Fully tighten bolts at end of this step.

	#83 M8X30mm 4PCS
	#71 M8 4PCS

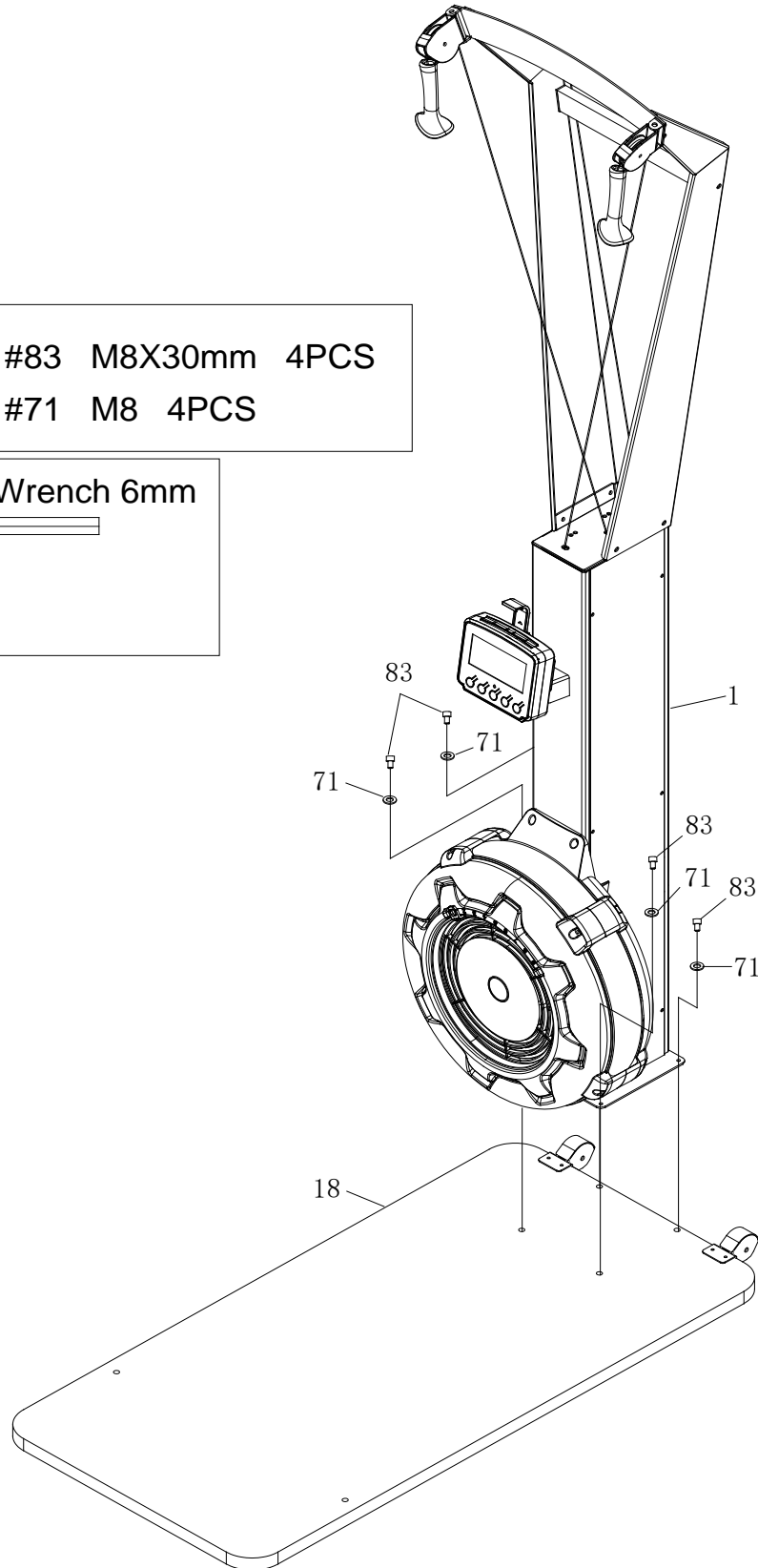
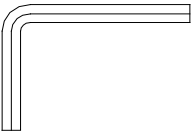

#89 Allen Wrench 6mm



STEP 11

Attach the **U-bar Bracket (6)** to **Main Body (1)** using: 2 PCs of **M8x50mm Button Head Cap Screw (84)**, **M8 Arc washer (85)**, and 1 PC of **U-bar Bracket Cushion (42)**.

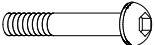
NOTE: Fully tighten bolts at end of this step.

	#84 M8X50mm 2PCS
	#85 M8 2PCS

#90 Allen Wrench 5mm

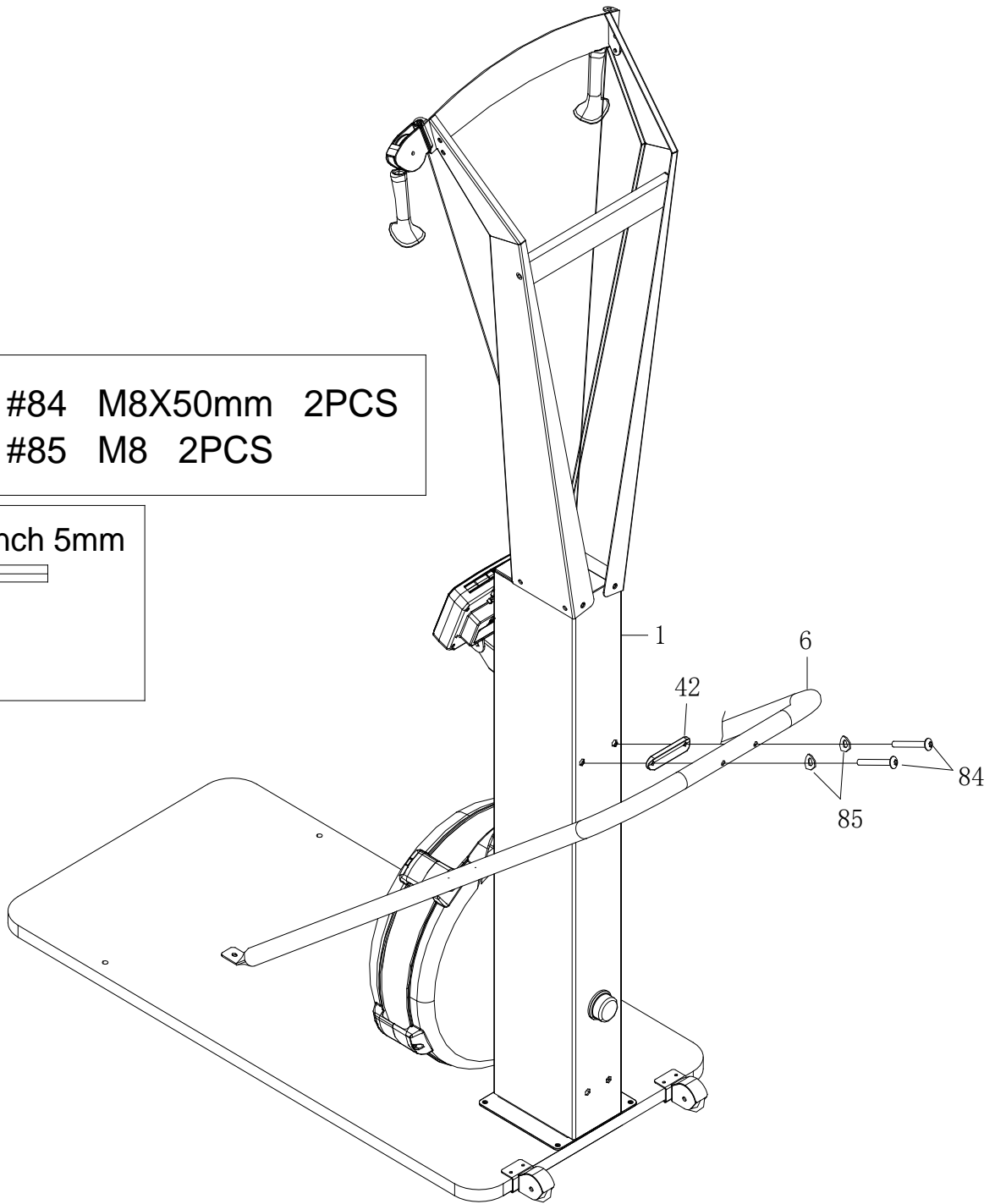
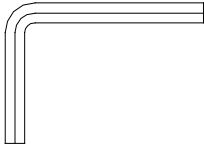

STEP 12

Attach the **U-bar Bracket (6)** to **Wooden Base (18)** using: **M8x30mm Socket Head Screw (83)** and **M8 Flat Washer (71)**.

Tighten all screws on the **U-bar Bracket(6)**.

NOTE: Fully tighten bolts at end of this step.

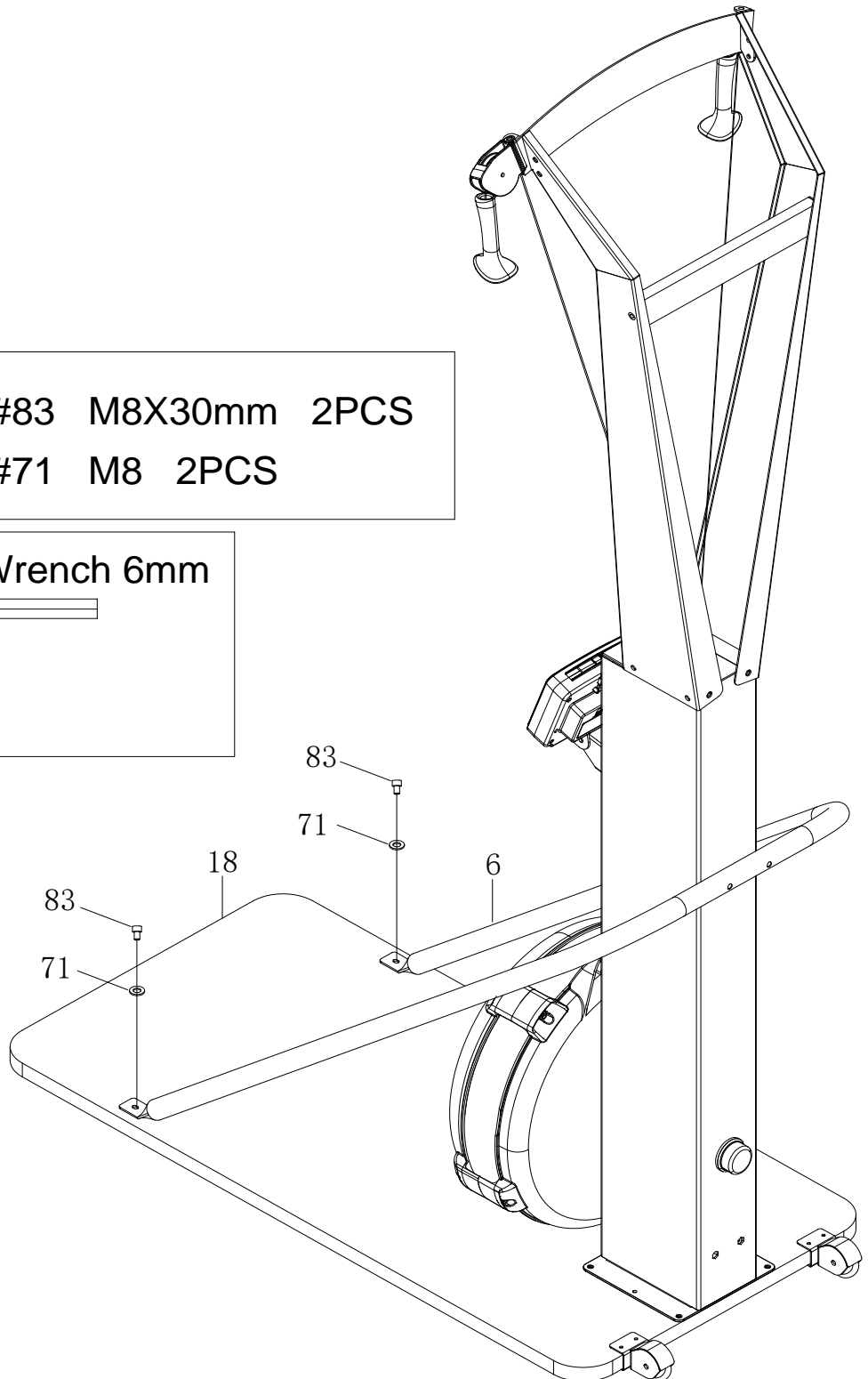
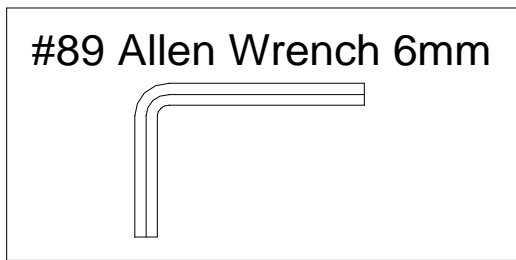
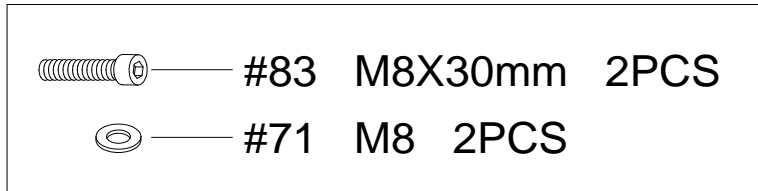

COMPUTER INSTRUCTIONS

Your **SKI ERGO** utilizes an air fan system to create resistance for your workout. We recommend that you use this computer console to vary your workout from session to session and note your progress toward your fitness goals. When used regularly in this way, the computer console can become an important source of motivation and interest which will help keep you on track.



INITIAL SETUP

POWER ON:

- Move the handlebar to start exercising in Quick start program or press any button to go into IDLE mode.

POWER OFF:

- In IDLE mode, automatically shuts off after 20 seconds of inactivity.
- When running an Interval Program, automatically shuts off after 2 minutes of inactivity
- In all other programs, automatically shuts off after 30 seconds of inactivity.

METRIC & STANDARD UNIT:

- The initial factory setting is in "KM". To toggle between Miles and Kilometers, press and hold "UP" and "DOWN" buttons when console in IDLE mode, it will display flashing "KM" & "MILE". Press "UP" or "DOWN" arrows to select "KM" or "MILE" and then press "ENTER" to confirm.

BATTERY INSTALLATION:

- Console operates on 2 Size C batteries. The battery compartment is on the back of the console. Please install 2 Size C batteries in console monitor before the workout.
- When there's no batteries installed, console can still work in Quick start program.

FUNCTION BUTTONS

SELECT BUTTON:

- In IDLE mode, press and release **SELECT** to cycle through each program option. Stop on the program of your choosing. You can preset target values for DISTANCE, TIME, and CALORIES, GAME, or select an Interval Program of 20/10, 10/20, or 10/10.

NOTE: Default exercising mode is Quick start program.

▲ (UP BUTTON):

- Press to increase the preset values. Press the button and hold it down, the presetting value will go faster, release the button to stop.

▼ (DOWN BUTTON):

- Press to decrease the preset values. Press the button and hold it down, the presetting value will go faster, release the button to stop.

BACK BUTTON:

- When selecting the programs, press the button to return to the previous program.
- When you finish a running program, press the button to jump into the IDEL mode.

ENTER/STOP BUTTON:

- When selecting the programs and presetting target values, press the button to confirm.
- Press the button and hold it down for three seconds to reset all functions to zero and restart the computer.
- During exercise, when back light is turned off, the first pressing of this button will turn on the back light. When the back light is still lit, press the button a second time to pause the counting of all function values. Press the button a third time to restart the workout and continue of the counting of all function values.

CONSOLE DISPLAY

STROKE RATE:

- Display the current stroke per minute during exercise.
- The lightened up semi-circle equals to the stroke rate that displayed in numbers. The more grids it shows, the higher your stroke rate is.

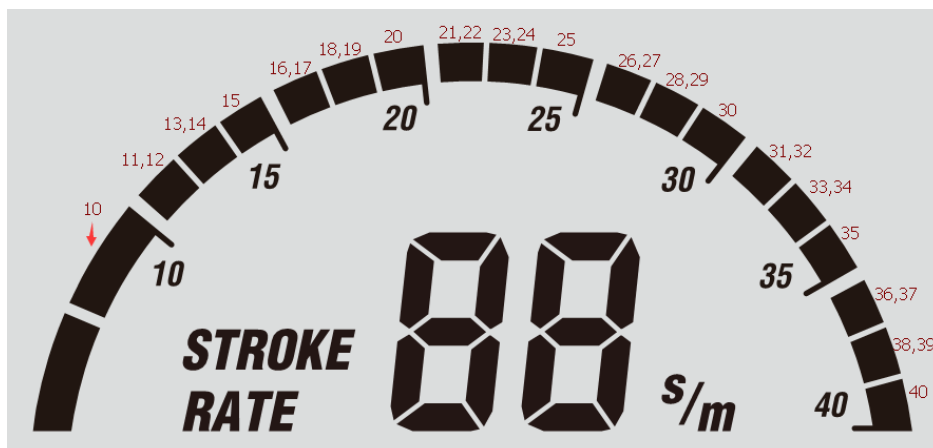

TIME & TIME/500m AVG:

- Display range: 00:00 ~ 99:59 minutes.
- The workout time is accumulated when under any workout mode.
- Display flashing "00:00" for presetting the TIME (countdown) program. Time can be set from 1:00 to 99:00 minutes.
- Time cannot be saved under 10/10 INTERVAL program. Setting range is 10 ~ 99.
- The time/500mAVG is the average time per hour for reaching distance of 500 meters.

TIME/500m:

- Display range: 00:00 ~ 99:59 minutes.
- The time/500m is the current time per hour for reaching distance of 500 meters.

WATTS AVG & PULSE:

- Display range for watts AVG: 0 ~ 999 watts.
- Display the average amount of power generated during the workout.
- Display the heart rate from 40 to 220 beats per minute during exercise. To use this function, the user must wear Heart Rate Chest Strap.

DISTANCE & DIST/30MIN:

- Display range: 0 ~ 9999 meters. It's accumulated in cycle mode that numbers go back to 0 if the distance exceeds 9999 meters.
- The workout distance is accumulated when under any workout mode.
- Display flashing "500" for presetting DISTACNE (countdown) program. The target distance value can be set from 500 to 9999 meters.
- The dist/30min is the estimated distance for 30 minutes with the current stroke rate.

CALORIES & CAL/HOUR:

- Display range: 0 ~ 999 cal.
- Display flashing "100" for presetting CALORIES (countdown) program. The target calories value can be set from 10 to 999 cal.
- The cal/hour is the average calories consumed per hour during the workout.

CYCLE & WATTS:

- Display only in INTERVAL program.
- Display flashing "8" for presetting the target rounds of exercise in INTERVAL program. The target cycle value can be set from 1 to 99 rounds.
- Display range: 0 ~ 999 watts.
- Display the amount of power generated at any moment during the workout.

LOW BATTERY REMINDER:

- Display battery symbol only when the battery is low.

PROGRAMS

The Console Monitor has eight programs: QUICK START, TIME (countdown), DISTANCE (countdown), CALORIES (countdown), GAME, and INTERVAL PROGRAMS of 20/10, 10/20, & 10/10.

Press "Select" to change workout program according to the following sequence: Quick Start → Distance → Time → Calories → Game → 20/10 Interval → 10/20Interval → 10/10 User Setting Interval

1. QUICK START PROGRAM

- To Quick Start the program, you can pull on the Handlebar(3) to start. All function values for the console will count up.
- Press "**STOP**" button once to temporarily stop counting all values (Pause function). Pull the Handlebar (3) again to continue the counting. Long press "**STOP**" button to delete all counting data.
- For Quick Start and all three countdown programs, press "**SELECT**" button to choose the data displayed in the same display window, including Time & Time/500m AVG.
- For the other seven programs, press "**BACK**" button to enter IDLE mode. Or press and hold "**ENTER/STOP**" button for over 3 seconds to re-start the console. Use "**SELECT**" button to toggle between programs. Use "**UP**" and "**DOWN**" buttons to adjust the value and press "**ENTER/STOP**" to confirm.

2. DISTANCE (Countdown) PROGRAM

- During the workout, the "**DISTANCE**" program will count down from preset value.
- The program will start once the user pulls the Handle (44). When the program is finished, the monitor will show "**WINNER**" with an audible alarm. Press the "**BACK**" button to go to the IDLE mode.

3. TIME (Countdown) PROGRAM

- During the workout, the "**TIME**" program will count down from preset value. The program will start once the user pulls the Handle (44). When the program is finished, the monitor will end with an audible alarm. Press "**BACK**" button to go to the IDLE mode.

4. CALORIES (Countdown) PROGRAM

- During the workout, the "**CALORIES**" program will count down from preset value. The program will start once the user pulls the Handle (44). When the program is finished, the monitor will show "**END**" with an audible alarm. Press "**BACK**" button to go to the IDLE mode.

5. GAME PROGRAM

- When the "GAME" program is selected, the program will start once the user pulls the Handlebar. There is no presetting value to be entered. When the program is finished, the monitor will show your score with an audible alarm. Press the "BACK" button to go to the IDLE mode.

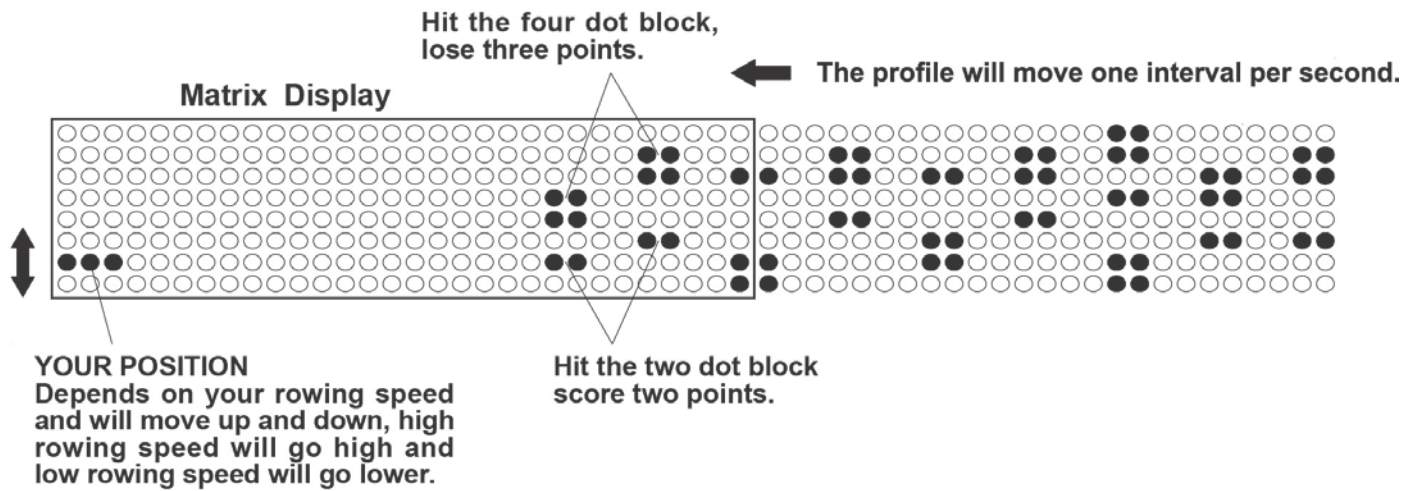

6. 20/10 INTERVAL PROGRAM

- When it is in the "20/10 INTERVAL" program, the console monitor will display flashing "8" for presetting value of cycle. "20" is 20 seconds for exercising, and "10" is 10 seconds for resting. Then user can use "UP" and "DOWN" buttons to input the value from 1 to 99. The user will workout for 20 seconds and then rest for 10 seconds. When the program is finished, the monitor will end with an audible alarm. Press the "BACK" button to go to the IDLE mode.

7. 10/20 INTERVAL PROGRAM

- When it is in the "10/20 INTERVAL" program, the console monitor will display flashing "8" for presetting value of cycle. Then user can use "UP" and "DOWN" buttons to input the value from 1 to 99. User will workout for 10 seconds and then rest for 20 seconds. The program will start once the user pulls the Handle (44). When the program is finished, the monitor will end with an audible alarm. Press the "BACK" button to go to the IDLE mode.

8. 10/10 INTERVAL PROGRAM

- When it is in the "10/10" INTERVAL" program, the console monitor will display flashing "8" for presetting value of cycle. Then user can use "UP" and "DOWN" buttons to input the value from 1 to 99 for number of cycle, workout time, and rest time. The program will start once the user pulls the Handle (44). When the program is finished, the monitor will end with an audible alarm. Press the "BACK" button to go to the IDLE mode.

OPERATIONAL INSTRUCTIONS

LOAD ADJUSTMENT

There is a **Damper (31)** built into the **Upper Fan Shroud (32)**. Move the Indicator in the **Damper (31)** to point to the numbers on the **Upper Fan Shroud (32)** to adjust the load. There are settings from 1 to 9. Setting #1 will provide the lowest resistance. Setting #9 will provide the highest resistance.

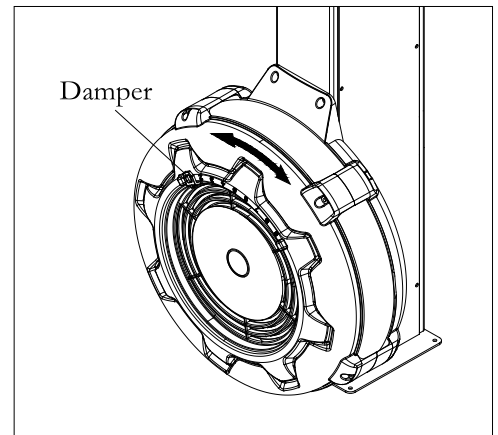

USING THE CELL PHONE BRACKET

The **Cell Phone Bracket (15)** can move up and down. Move up the **Cell Phone Bracket (15)**, then slide the Cell Phone into the gap between the **Cell Phone Bracket (15)** and the **Console Monitor (14)**. Move down the **Cell Phone Bracket (15)** to clip the Cell Phone in position.

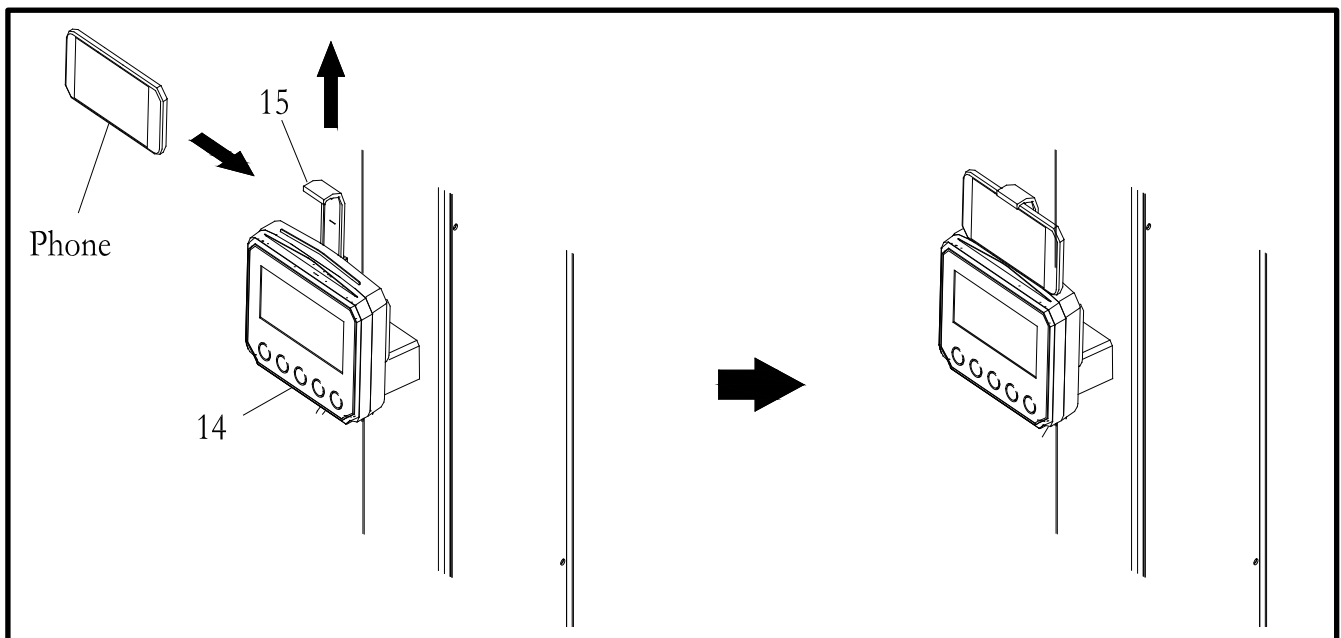

MAINTENANCE

The safety and integrity designed into the **ERGO SKI 3.0** can only be maintained when the **ERGO SKI 3.0** is regularly examined for damage and wear. Special attention should be given to the following:

1. Pull on the **Handle (44)** and verify that the System provides tension and the seat travel is smooth and stable.
2. Clean the revealed surface of **Cord Pulley (27)** with an absorbent cloth.
3. Verify that all nuts and bolts are present and properly tightened. Replace missing nuts and bolts. Tighten loose nuts and bolts.
4. Check the condition of the **Drive Cord (52)**. Replace the **Drive Cord (52)** if it is damaged or broken.
5. Verify that the **Warning Label** is in place and easy to read.
6. It is the sole responsibility of the user/owner to ensure that regular maintenance is performed.
7. Worn or damaged components must be replaced immediately or the **ERGO SKI 3.0** removed from service until repair is made.
8. Keep your **ERGO SKI 3.0** clean by wiping it off with an absorbent cloth after use.

STORAGE

1. To store the **ERGO SKI 3.0**, simply keep it in a clean dry place.
2. To avoid damage to the electronics, remove the batteries from the **Console Monitor (14)** before storing the **ERGO SKI 3.0** for one year or more.
3. Move the **ERGO SKI 3.0** with the **Transport Wheels (49)** on the **Wooden Base (18)**. Lift one end of **Wooden Base (18)** to move the **ERGO Ski 3.0**. Refer to the illustration below. Do not use the **U-bar Bracket (6)** to move the **ERGO Ski 3.0**. It may cause danger.

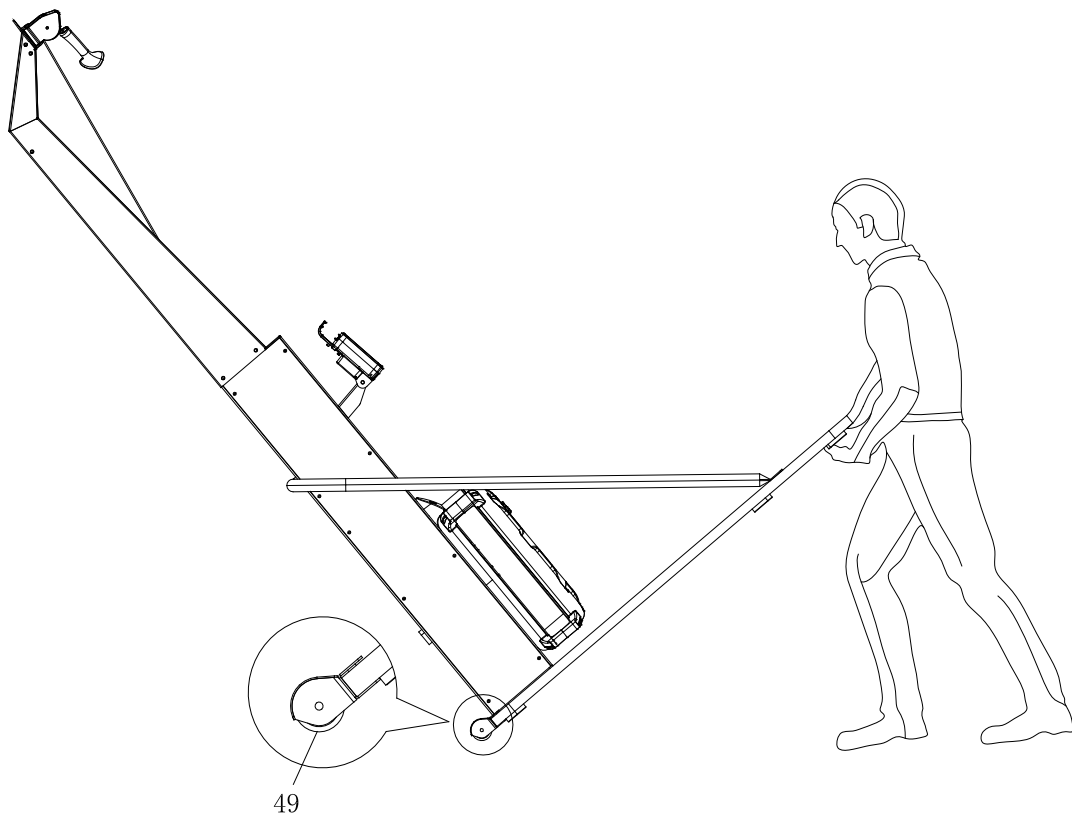

PRODUCT PARTS DRAWING

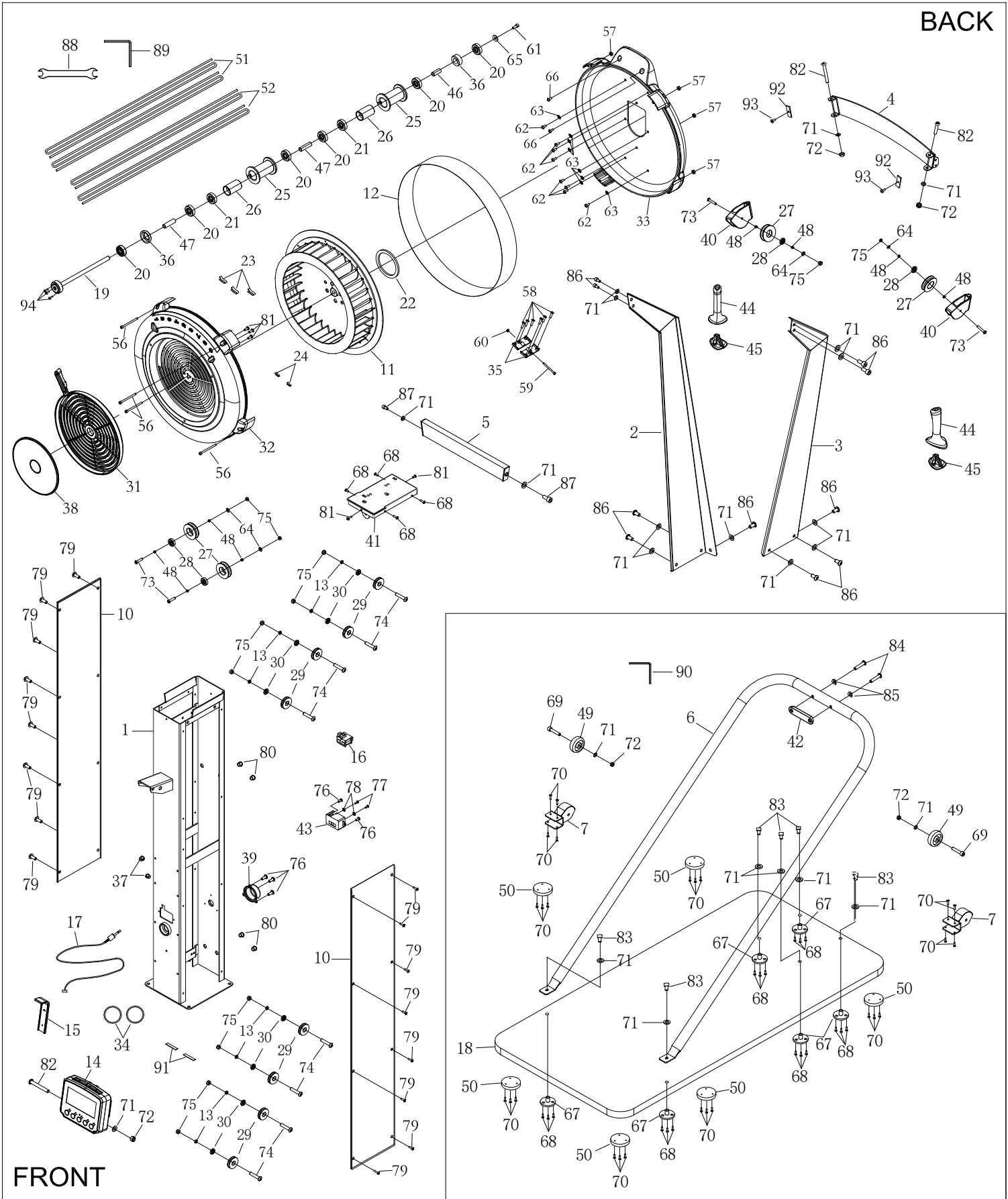

PARTS LIST

PART#	DESCRIPTION	QTY
1	Main Body	1
2	Left Upper Arm	1
3	Right Upper Arm	1
4	Top Bracket	1
5	Arm Connection Bracket	1
6	U-bar Bracket	1
7	Transport Wheel Cover	2
10	Body Cover (Left/Right)	2
11	Fan	1
12	Perforated Steel Mesh	1
13	Console Pulley Spacer	8
14	Console Monitor	1
15	Cell Phone Bracket	1
16	Generator	1
17	Sensor Cable	1
18	Wooden Base	1
19	Fan Axle	1
20	Bearing 6001RS	6
21	One Way Bearing (HF1212,12t)	2
22	Magnet	1
23	Balance Weight	3
24	Small Balance Weight	2
25	Cord Pulley	2
26	Pulley Spacer	2
27	Cord Pulley	4
28	Bearing 6000ZZ	4
29	Console Pulley	8
30	Bearing 606ZZ	8
31	Damper	1
32	Upper Fan Shroud	1
33	Bottom Fan Shroud	1
34	Rubber Band	2
35	Steel Plate	2
36	Bushing 6001	2
37	Cable Plug	2

38	Damper Cap	1
39	Pulley Cover	1
40	Pulley Bracket	2
41	Body Upper Cover	1
42	U-bar Bracket Cushion	1
43	Generator Base	1
44	Handle	2
45	Handle Plug	2
46	Short Spacer	1
47	Long Spacer	2
48	Cord Pulley Spacer	8
49	Transport Wheel	2
50	Wooden Base Cushion	6
51	Bungee Cord	2
52	Drive Cord	2
56	Socket Head Cap Screw, M5x92mm	4
57	Hex Nut, M5	4
58	Philips Head Screw, ST4.2x6mm	6
59	Philips Head Screw, M4x45mm	1
60	Hex Nut, M4	1
61	Socket Head Cap Screw, M6x12mm	1
62	Philips Head Screw, M6x10mm	8
63	Lock Washer, Internal Tooth M6	8
64	Flat Washer, M6	4
65	Flat Washer, $\varnothing 16 \times \varnothing 6.2 \times 1.5 \text{mm}$	1
66	Philips Head Screw, M6x16mm	2
67	Cushion Nut, M8	6
68	Philips Head Screw, ST4.2x16mm	22
69	Socket Head Cap Screw, M8x40mm	2
70	Philips Head Screw, ST4.2x25mm	26
71	Flat Washer, M8	25
72	Nylon Nut, M8	5
73	Button Head Cap Screw, M6x35mm	4
74	Philips Head Screw, M6x20mm	8
75	Nylon Nut, M6	12
76	Philips Head Screw, ST4.2x10mm	5
77	Philips Head Screw, ST3.5x12mm	2
78	Flat Washer, $\Phi 12 \times \Phi 3.5 \times 1.0 \text{mm}$	2
79	Philips Head Screw, M5x8mm	16
80	Hex Nut, M8	4

81	Philips Head Screw, ST4.2x16mm	5
82	Button Head Cap Screw, M8x75mm	3
83	Socket Head Cap Screw, M8x30mm	6
84	Button Head Cap Screw, M8x50mm	2
85	Arc washer, M8	2
86	Socket Head Cap Screw, M8x12mm	10
87	Socket Head Cap Screw, M8x15mm	2
88	Wrench	1
89	Allen Wrench 6mm	1
90	Allen Wrench 5mm	1
91	EVA Single Glue	2
92	Rubber Cushion	2
93	Philips Head Screw, M5x8mm	2
94	Socket Head Cap Screw, M4x12mm	3