

Orbit **ST37A.4**

ST37A.4

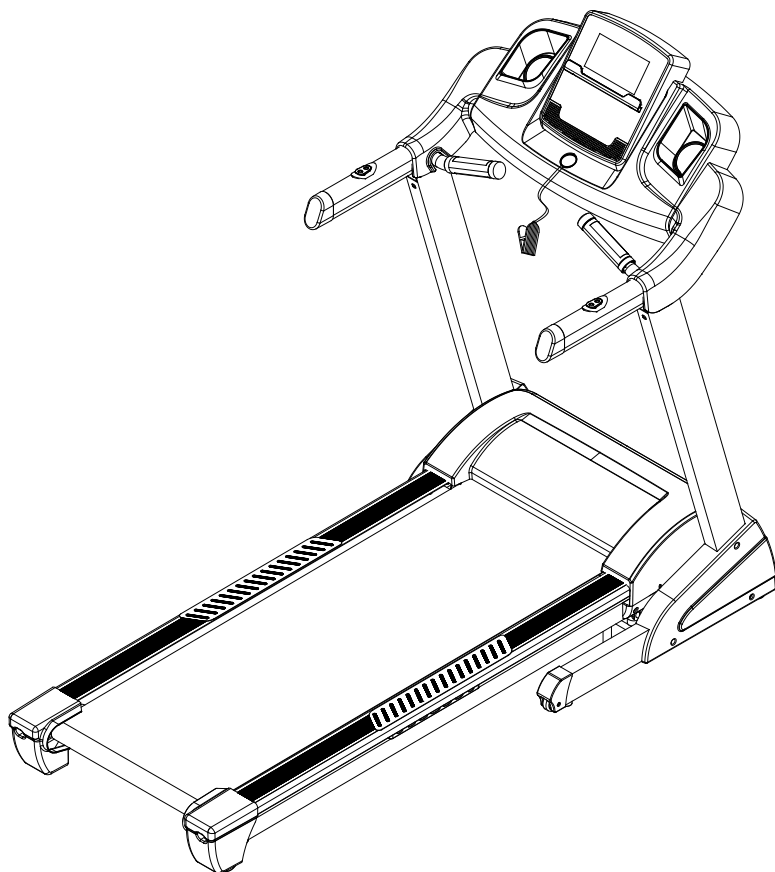

- **Warranty**
- **Assembly**
- **Parts**

**TOOL REQUIRED
FOR ASSEMBLY**
Adjustable Wrench
Pliers
Hammer

Owner's manual ST37A.4

CAUTION : 1. *Weight on this product should not exceed 264 lbs/120 kgs.*

2. *Exercise of a strenuous nature, as is customarily done on this equipment, should not be undertaken without first consulting a physician. No specific health claims are made or implied as they relate to the equipment. Measurements made by the equipment are believed to be accurate, but only The measurements of your physician should be relied upon.*

IMPORTANT: *Read all instructions carefully before using this product. Retain this product. Owner's manual for future reference.*

CONTENT

CONTENT	1
IMPORTANT SAFETY PRECAUTIONS	2
ASSEMBLY INSTRUCTIONS	3-5
FOLDING & UNFOLDING INSTRUCTIONS	6
GROUNDING METHODS	7
OPERATION GUIDE	8-14
GETTING STARTED GUIDE	15
SAFETY EXERCISES	16
WARM-UP EXERCISES	17
MAINTENANCE INSTRUCTIONS	18
BELT ADJUSTMENT	19
EXPLODED DRAWING	20
PARTS LIST	21-22
ERROR CODE AND TROUBLE SHOOTING	23



IMPORTANT SAFETY PRECAUTIONS

WARNING: Before starting any exercise program, consult your physician or health professional, especially for person who is above 35 years old or had some health problems before. Neither manufacturer nor distributor should be held responsible for any injuries or discomfort by the user due to above reasons. Don't plug in power until you finish assembling the treadmill.

ATTENTIONS:

1. When using this treadmill, attach the safety key pull pin to your clothes or belt.
2. Do not plug anything into any parts of this treadmill, or it may cause damage.
3. Position treadmill on a clean, level surface. Do not place the treadmill on thick carpet as it may interfere with proper ventilation. Whereby necessary, use a rubber or PVC treadmill mat. Do not place treadmill near water or outdoors, moisture will cause damage to electronics.
4. Do not start the treadmill while standing on the walking belt. After turning the power on and adjusting the speed control, there may be a few seconds before the walking belt begins to move, always stand on the foot rails on the sides of the frame until the belt is moving. Hold onto handrails when initially start walking or running on the treadmill, let go until you are comfortable with its speed.
5. Wear appropriate clothing when exercising on the treadmill. Do not wear long, loose fitting clothing that could be caught in the treadmill. Always wear running or aerobic shoes with rubber soles.
6. Keep small children and pets away from the treadmill while switched on.
7. This treadmill is designed for adult use, children intent to use the treadmill must have adult supervision.
8. The power cord of motorized treadmill is specialized for its purpose. Do not attempt to modify or repair it yourself. Do not place heavy object on power cord or leave it near high temperature, only plug it into well earthed power point. If it is damaged, please purchase new from distributor or contact our company directly.
9. In case of an electrical failure or safety key being pulled from its pot during exercise, this treadmill may come to a stop in 3-4 seconds. Hold onto hand rail until it completely stops and step down through the side foot rails. Do not attempt to jump off the treadmill while it's still in motion.
10. When the treadmill is not being used, unplug power cord and remove safety pull pin. Keep them in safe place and do not use them for other purpose.
11. This treadmill is designed for home use only with maximum user weight 120kg. It is improper to put it into a corporate or commercial environment and it won't be covered by its domestic warranty.

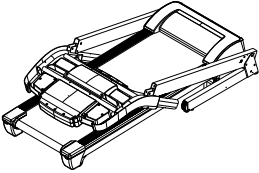
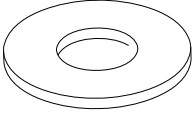
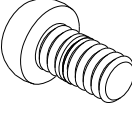
WHEN YOU OPEN THE CARTON, YOU WILL FIND THE BELOW PARTS:

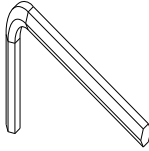
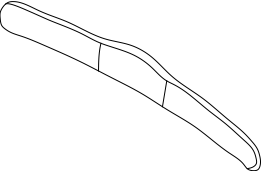
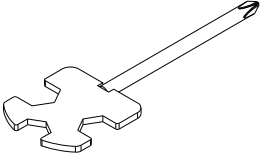
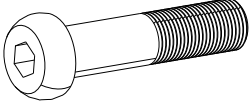
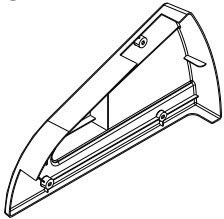
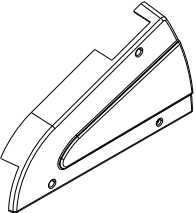
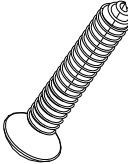
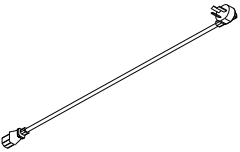
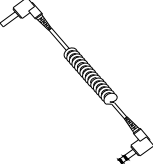
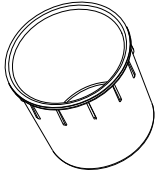
<p>Main frame 1set</p> 	<p>D21 Washer M10 8 PCS</p> 	<p>D8 Round head hex bolt M10*15 4 PCS</p> 	<p>C13 Safety key 1 PC</p> 
<p>D2 Allen wrench 6mm 1 PC</p> 	<p>C37 Chest belt 1PC</p> 	<p>D1 Screw driver 1 PC</p> 	<p>D12 Round head hex bolt M10*55 4 PCS</p> 
<p>B11L Left side cover 1 PC</p> 	<p>B11R Right side cover 1PC</p> 	<p>D48 Cross self-tapping bolt ST4.2*19, washer 6 PCS</p> 	<p>C15 Power cable 1 PC</p> 
<p>C19 MP3 cable 1 PC</p> 	<p>B49 Bottle holder 2 PCS</p> 		

NOTE: Do Not Tighten Bolts At Once.

STEP 1: Follow the below diagram to lift up the computer bracket. Be careful not to cut, jam and damage cables inside the frame tubes when folding up.

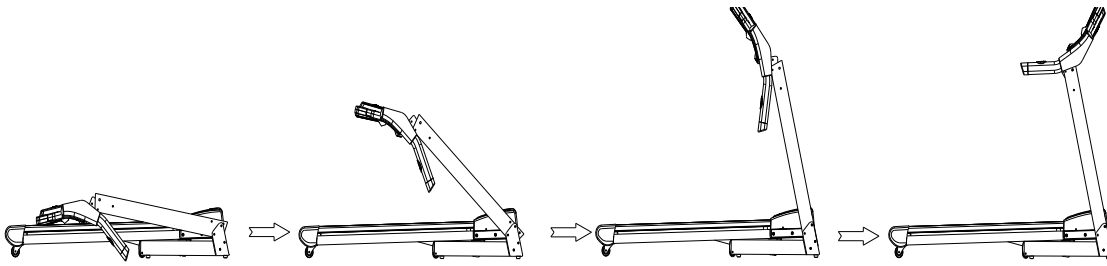

STEP 2: Use bolt M10*55 (D12) and flat washer M10 (D21) to tighten bottom uprights, and fix console/handrail bracket with bolt M10*15 (D8) and flat washer M10 (D21).

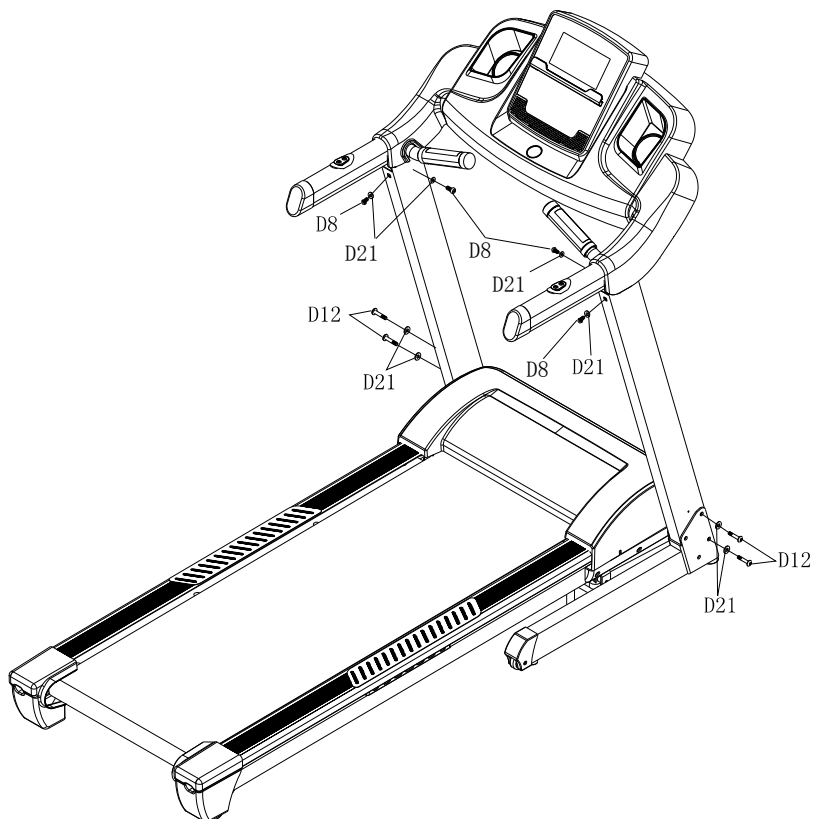

Step 3: Tighten left/right side covers (B11L/R) with cross self-tapping bolt ST4.2*19, washer (D48).

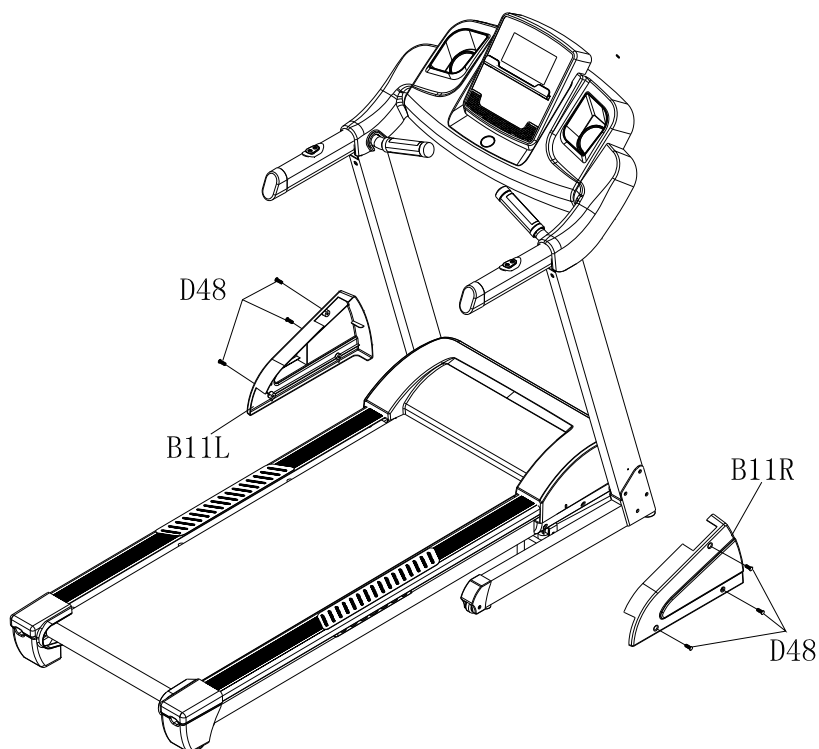

Step 4: Place on bottle holders (B49), safety key (C13), MP3 cable (C19), and power cable (C15).

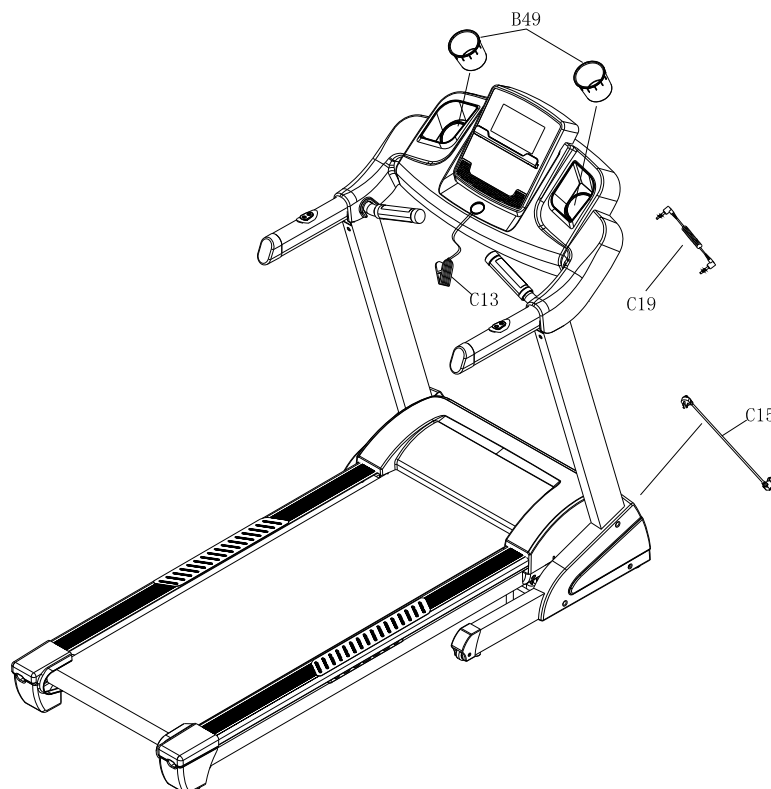

ATTENTION: Check that all nuts and bolts are tightened before using the treadmill. Please read the below instructions carefully.

Folding instruction

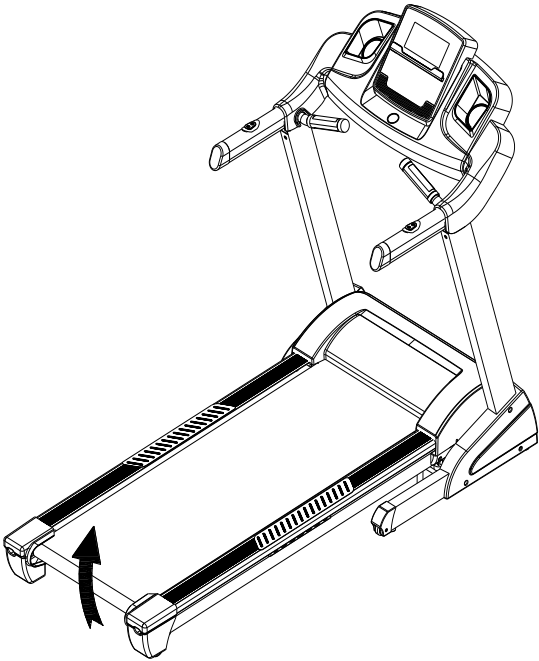

Lift up the machine and apply force to push up until you hear "click" from the latch, which indicates that locking mechanism is engaged.

Unfolding instruction

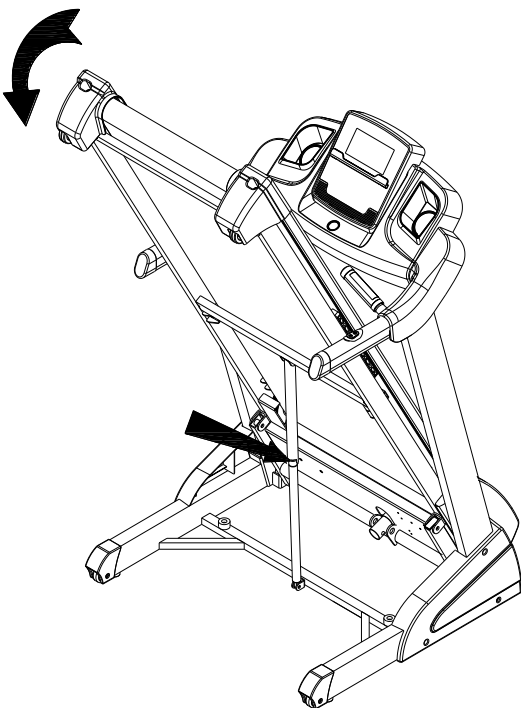

Use foot to press the latch lightly until the cylinder disengages and treadmill deck starts folding down. Hold onto the deck to support the fold down until you are in safe space to the drop. Let go and the deck will drop slowly (soft drop) until it reaches ground.

Grounding methods

This treadmill must be grounded properly. It is equipped with a cord connecting to an equipment-grounding conductor and a grounding plug. The 3 pin plug must be plugged into an appropriate power outlet that complies with industrial codes and local requirements in relate to grounding.

DANGER – Improper connection of the equipment-grounding conductor can result in risk of electric shock. Check with a qualified electrician or serviceman if you are in doubt as to whether the product is properly grounded. Do not modify the plug provided with the product. If it does not fit the power outlet, please have a proper outlet installed by a qualified electrician. No adapter should be used with this product.

Operation Guide



1.2. START

Treadmill starts after 5 seconds of countdown.

1.3 PROGRAM

1 manual mode, 16 pre-set programs, 3 countdown functions, 1 body fat program, 3 users programs, 3 HRC programs.

1.4. SAFETY LOCK FUNCTION

Window shows "---" when safety key is taken away from the lock and treadmill will stop quickly with "didi" beeping alarm. Put the safety key back on and all windows will light up for 2 seconds and then show 0 or default values.

1.5 BUTTON FUNCTION

1.5.1. START/STOP/PAUSE

“START”--When treadmill is switched on, press this button to start. The initial speed is “1.0”.

“STOP”--When treadmill is running, press this button ONCE for a temporary stop (PAUSE function) with exercising data remained. Press START button when treadmill is at Pause Condition, it will resume previous speed and the incline level stay unchanged.

Press STOP button TWICE for a complete stop in a few seconds and program will return to manual mode.

1.5.2 “PROGRAM” BUTTON

When treadmill is switched on, press this button to have exercise options from manual mode to pre-set modes (P1-P16,1 Body fat, U1-U3, HRC programs).

1.5.3 “MODE” BUTTON

When treadmill is switched on, press this button to choose countdown modes:”H-1”,”H-2”,”H-3”;

H-1” is the time countdown mode, “H-2” is the distance countdown mode, “H-3” is the calorie countdown mode;

press “SPEED+/-” or “INCLINE+/-“button to adjust the set values to desired values. After that, press “START” button to start the treadmill.

1.5.4 “SPEED +/- “BUTTON

SPEED +/- --Adjust speed when treadmill starts, the increment is 0.1km with each press. Hold on button for continuous adjustment.

1.5.5 SPEED QUICK BUTTON

Press speed quick button 4km/h, 6km/h, 8km/h, 10km/h, 12km/h , 16km/h, 18km/h to adjust speed towards the desired speed when the treadmill is running.

1.5.6 “INCLINE+/-” BUTTON

INCLINE +/- --Adjust incline when treadmill starts; the increment is 1 section with each press. Hold on the button for continuous adjustment.

1.5.7 INCLINE QUICK BUTTON

Press incline quick button 2,4,6,8,10,12,15 to adjust incline level towards desired level when the treadmill is running.

1.6. DISPLAY FUNCTION

1.6.1 SPEED

Display running speed in km/h.

1.6.2 TIME

Display total accumulated running time or countdown time left in a program.

1.6.3 DISTANCE

Display accumulated total distance or distance countdown.

1.6.4 CALORIE

Display accumulated calorie burnt or calorie countdown.

1.6.5 INCLINE

Display incline level in 15 increments.

1.6.6 PULSE

Display pulse data.

1.6.7 ALL WINDOW DISPLAY DATA RANGE

TIME: 0:00 – 99.59(MIN)

DISTANCE: 0.00 – 99.9(KM)

CALORIES: 0.0 – 999 (kcal)

SPEED:1-20.0(km/h)

PULSE: 50 – 200 (BPM)

INCLINE: 0 – 15 level

1.7 PULSE FUNCTION

When the treadmill is running, hold on hand pulse pads for about 5 seconds, it will then display your pulse reading. A heart-shaped symbol will flash when testing pulse. The heart rate measurement is only good as exercise reference and can not be used as medical data.

1.8 PROGRAM EXERCISE CHART

		1	2	3	4	5	6	7	8	9	10	11	12	13	14	15	16
P01	SPD	2	5	5	5	10	10	5	5	5	3	3	2	5	5	3	2
	INC	0	0	1	1	1	1	2	2	2	2	3	3	3	2	2	0
P02	SPD	2	2	7	2	2	7	7	12	4	4	12	4	4	12	4	2
	INC	0	1	2	2	3	3	2	2	3	3	2	2	3	2	2	0
P03	SPD	2	4	9	9	4	4	8	8	10	10	12	4	4	8	4	2
	INC	0	1	2	3	4	5	4	5	4	2	1	2	3	2	1	0
P04	SPD	2	6	6	6	12	12	12	12	6	6	3	3	3	5	5	2
	INC	0	1	2	3	4	5	6	7	6	6	5	4	3	2	1	0
P05	SPD	2	4	6	12	12	12	3	3	3	3	12	12	12	6	4	2
	INC	0	2	4	6	4	2	1	0	1	1	2	2	2	2	3	0
P06	SPD	2	4	5	5	6	6	8	8	6	6	8	8	6	9	6	2
	INC	0	1	3	4	4	3	3	1	2	1	2	1	2	1	2	0
P07	SPD	2	7	7	9	9	4	4	12	12	4	4	8	8	4	4	2
	INC	0	1	1	2	2	3	3	4	4	3	3	2	2	1	1	0
P08	SPD	2	2	6	6	6	8	9	10	11	12	9	5	5	5	3	2
	INC	0	1	2	4	2	1	2	4	2	1	2	4	2	1	2	0

P09	SPD	2	4	8	10	2	4	8	10	2	4	10	2	4	10	4	2
	INC	0	1	2	3	4	5	6	7	8	9	8	6	4	2	1	0
P10	SPD	2	5	6	7	8	9	10	11	10	9	8	6	7	5	4	2
	INC	0	1	2	4	6	6	6	4	4	4	2	2	2	1	1	0
P11	SPD	2	5	6	7	9	9	6	9	6	9	6	10	6	10	7	2
	INC	0	2	2	2	3	3	3	4	4	4	5	5	5	4	4	0
P12	SPD	2	6	8	10	8	6	4	6	8	12	8	6	8	12	12	2
	INC	0	1	1	3	3	5	5	7	7	5	5	3	3	1	1	0
P13	SPD	2	12	4	12	4	12	4	12	4	12	4	12	4	12	4	2
	INC	0	8	10	13	4	8	10	13	4	8	10	13	4	8	10	0
P14	SPD	2	8	10	12	4	8	10	12	4	8	10	12	4	8	10	2
	INC	0	8	12	13	4	8	12	13	4	8	12	13	4	8	12	0
P15	SPD	2	12	10	8	12	12	10	8	12	12	10	8	12	12	10	2
	INC	0	3	4	5	6	8	7	8	8	7	7	6	5	4	3	0
P16	SPD	2	12	4	12	4	12	4	12	4	12	4	12	4	12	4	2
	INC	0	4	5	6	2	4	5	6	2	4	5	6	2	4	5	0

1.9 Manual mode operation

1.9.1 Press start key, time counts down 5 seconds, then treadmill will start to work with initial speed 1km/h.

1.9.2 Press speed +/- to adjust speed.

1.9.3 Press incline +/- to adjust incline.

1.9.4 Press stop, you can stop treadmill at anytime.

1.9.5 Press quick speed key, you can quickly adjust speed to what you want.

1.9.6 Press quick incline key, you can quickly adjust incline to what you want.

1.10 3 COUNTDOWN FUNCTION PARAMETER DATA

1.10.1 Countdown time initial setting: 15: 00 minutes. Available range: 5: 00---99: 00 minutes.

Each interval: 1: 00.

1.10.2 Countdown calorie initial setting: 50 kcal. Available range: 10-990 kcal. Each Interval: 10.

1.10.3 Countdown distance initial setting: 1.0km. Available range: 0.5---99.9 km. Each interval: 0.1km.

Options are set in order as: manual, time, distance, calories.

1.11 BODY TESTER (FAT)

After switching on treadmill, press "PROGRAM" repeatedly until window displays "FAT"

Press "MODE" to enter (F1 SEX, F2 AGE, F3 HEIGHT, F4 WEIGHT). Press "SPEED+",

"SPEED-" to set. After above data entry, computer will display F5 and please grasp hand pulse pads for a few seconds and window will display your body quality index.

Body quality index is based on calculation between average height and weight. It can be used in weight control programs together with other body quality index

The ideal FAT should be between 20-25, if under 19, it means too thin. If between 25 and 29, it means overweight, if over 30, it means obese. (The Index is a loose definition and should only be treated as reference, not for medical purpose)

- 01 Sex 01 Male 02 Female
- 02 Age 10-----99
- 03 Height 100----200 cm
- 04 Weight 20-----150
- 05 FAT≤19 Under weight
- FAT= (20---25) Normal weight
- FAT= (25---29) Over weight
- FAT≥30 Obesity

1.12 User Program

Besides 15 pre-set programs, there are 3 user-defined programs:U1,U2 and U3. Each user program has 20 segments. The user can set the desired speed and incline .Press "PROGRAM" button to choose U1 ,U2 or U3, press "MODE" button to enter setting condition, then set the time of the first segment. Press "SPEED+" and "SPEED-" to set speed. Press" INCLINE+" and "INCLINE-" to set incline. Press "MODE" button and your choice will be set. The next workout segment will flash, go through the same setup as you complete segment one. You must complete all 20 segments and then your user program is ready to use. Press "STOP" key to return to last segment setting any time.

1.13 Heart rate control (HRC) program

It is recommended that you use a heart rate chest belt (transmitter) when using HRC Programs; hand pulse pads may not be reliable for HRC programs

There are 3 HRC programs. HR1, HR2, HR3. The related T.H.R is $(220-AGE) \times 60\%$ (70% / 80%).The parameter data setting order is 『TIME』 → 『AGE』 → 『THR』 , You can adjust the data by pressing Speed+/- Key or Incline +/-Key, then press Mode key for confirmation.

If 『HR<THR-15』, then SPEED and INCLINE will adjust itself to make your heart rate close to the default pulse automatically in every 15secs, SPEED will automatically increase by 0.8KM every stage, after reaching the max. SPEED, INCLINE will automatically increase by 1 level every stage until reaching the max. INCLINE.

If 『THR-5 > HR ≥ THR-15』, then SPEED and INCLINE will adjust itself to make your pulse close to the default pulse automatically in every 15secs, SPEED will automatically increase by 0.4KM every stage, after reaching the max. SPEED, INCLINE will automatically increase by 1 level every stage until reaching the max. INCLINE.

If 『THR+5 ≥ HR ≥ THR-5』, then SPEED and INCLINE will not change

If 『THR+15 ≥ HR > THR+5』, then SPEED and INCLINE adjust itself to make your pulse close to the default pulse automatically in every 15 secs, INCLINE will automatically decrease by 1 level every stage, after reaching the min. INCLINE, SPEED will automatically decrease by 0.4KM every stage until reaching the min. SPEED.

If 『HR > THR+15』, then each 15secs SPEED and INCLINE adjust itself to make your pulse close to the default pulse automatically in every 15 secs, INCLINE will automatically decrease by 1 level every stage, after reaching the min. INCLINE, SPEED will automatically decrease by 0.8KM every stage until reaching the min. SPEED.

1.14 Bluetooth Apps

Press bluetooth button to turn it on, and connect one o compatible apps at one time. The apps include (1) iConsole+, (2) Fit Hi Way, (3) iRunning (for iPad only) (4) Kinomap, and (5) Zwift

iConsole+ and Kinomap are the apps that can access to Google map with 2D map function.

Zwift allow users to train in a virtual world.

Pair the bluetooth before using any of the apps. Fit Hi Way requires to do the pairing again after turning on the app.



1.15 OTHERS

1.15.1 The system will enter into power saving mode automatically if there is no mat movement in 10 minutes under IDLE MODE. Display will shut down and backlit windows will switch off on the computer. Press any key to resume.

1.15.2 Countdown time, countdown calorie and countdown distance, you can only choose one of them at any time. While one window will show countdown time, distance or calorie, all other windows will display accumulated data as normal.

1.15.3 MP3 audio function: Insert MP3 cable in the input hole on the right side in the computer panel.

Note that music signals from MP3 and speaker may interfere with HR transmitter and receiver and make HRC program mal-function or in-accurate.

Getting started guide

PREPARE

If you are over 35 years old, or have health problems, or this is your first time to do fitness exercise, please consult doctor or professional before use this machine. If you're unsure of intensity and exercise time, please consult professional for advice.

Before you get onto the treadmill, please stand on solid ground to learn how to operate, such as start, stop and speed adjustment. After you familiar yourself with all the buttons and their respond time, stand on the foot rail on side of treadmill frame, hold onto handrails and start with 1.6--3.2 km/h low speed, stand straight, look forward, and adjust your pace to follow the speed of running belt, not faster not slower. After adapting well, you can then adjust speed to 3--5 km/h and further. Please allow some time for motor to pick up speed and do not set treadmill to any speed you're not familiar with or comfortable with.

EXERCISE

1 km casual walking takes about 15-25 minutes. Walk 1km by 4.8 km/h needs about 12 minutes. If you can do it easily for a few times, then adjust to higher speed and/or incline, and extend to walk/run for upto 30 minutes, you will have a good workout. For your health concern, do not over exercise.

AMOUNT OF EXERCISE

SHORTCUT—One recommended way is to do 15-20 minutes exercise.

Warm up for 2 minutes by 4.8 km/h, and adjust speed to 5.3 km/h and 5.8 km/h, continue to walk by these two speeds. Then add 0.3 km/h per 2mins speed increase, until you feel your heart beats quickly but you're not losing breathe. Keep the speed for 10-15 minutes. If feel uncomfortable, reduce speed by 0.3 km/h at a time. Leave 4 minutes for cool down at end of run. If you fell it is hard to intensify exercises by increasing speed, you can also choose to increase incline slowly. Some users may find it more effective.

Fat burn—This exercise may help you burn a lot calorie

Warm up 5 minutes by 4--4.8 km/h, add 0.3 km/h per 2 minutes, you can do 45mins on a speed that you feel comfortable yet carries some challenge. At last keep 4 minutes for cool down.

EXERCISE FREQUENCY

Target 3--5 times per week and 15-60mins each time. It is better to make a plan and stick to it. You can get the work-out you need by adjusting speed and incline and time of exercise.

SAFETY EXERCISE

Please consult professional staff before exercise, which can help recommend or draft exercise programs according to your age and health condition. When running, if you feel chest tightness or chest pain, irregular heartbeat, short of breathe, dizziness or anything uncomfortable, please stop exercise immediately! Seek medical advice if symptoms persist long after stop exercise.

Below setting is for your reference:

Speed 1-3.0 km	lack of exercise user or under health conditions
Speed 3.0-4.5 km	not regular exerciser
Speed 4.5-6.0 km	walker, low intensity
Speed 6.0-7.5 km	fast walker, high intensity
Speed 7.5-9.0 km	jogging
Speed 9.0-12.0 km	intermediate speed runner
More than 12.0 km	excellent runner, athletics

ATTENTION: It is best for walker to choose speed less than or equal to 6 km, recommend exercise for longer hours with less intensity

Warm-up Exercise

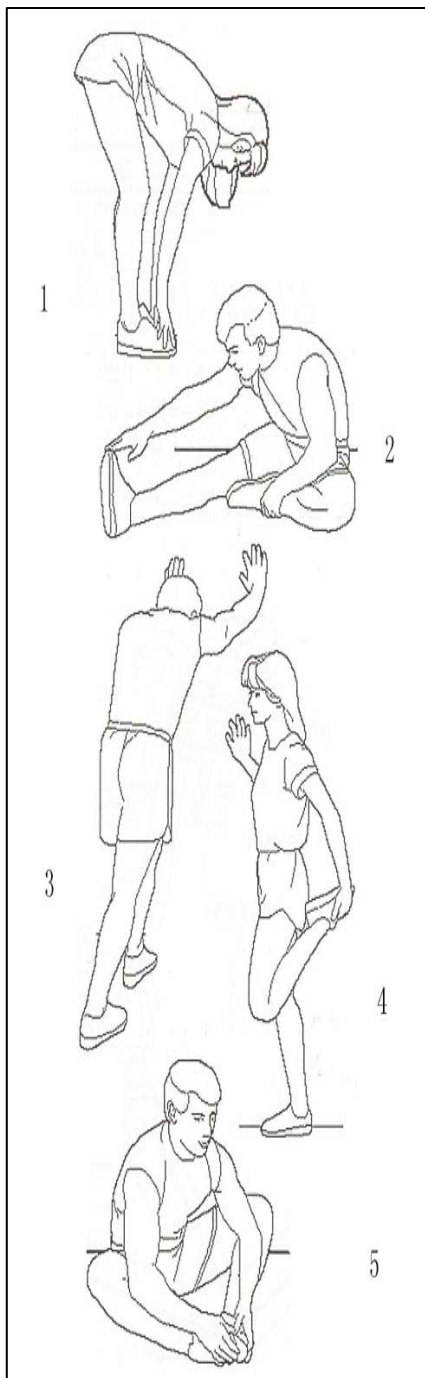

It is better to do some stretch exercise before running, this would help reduce chance of injury as well. Use 5-10 mins to warm-up. Follow below method and diagram to do stretch exercise for five repeats, and each foot for 10 seconds or more every repeat. After running, do those stretch exercises again.

1. Reach Down : Knees slightly bent and body slowly bent forward, back and shoulders relax, try to touch toes. Keep 10-15 seconds and relax. Repeat 3 times (See picture 1).

2. Hamstrings Stretch: Sitting on a clean cushion, put one leg straight, the other inward and close to the inside of the straight leg. Try to reach your toes with your hands. Keeping for 10 to 15 seconds, and relax. Repeat 3 times for each leg (See picture 2).

3. Crus and Feet Tendon Stretch: Standing with two hands on the wall or tree, one leg behind. Keeping your legs straight and heels on ground, tilt to the wall or tree. Keep 10 to 15 seconds, and relax. Repeat 3 times for each leg (See picture 3).

4. Quadriceps Stretch: Keeping your balance with your left hand holding on the wall or table, then stretch your right heel toward your buttocks slowly, until you feel very tense in the front of your thigh. Keep 10 to 15 seconds, and relax. Repeat 3 times for each leg (See picture 4).

5. Sartorius (Inner Muscles of the Thigh Muscle Stretch: Sitting down with your soles facing opposite and knees outward Pull your feet toward your groin. Keep 10 to 15 seconds, and relax. Repeat 3 times (See picture 5).

Maintenance Instruction

WARNING: Please make sure pull out treadmill's power plug from power supply before cleaning or maintenance, fail to do so may result in electric shock.

CLEANING: Regular cleaning of the unit will greatly prolong the treadmill's life.

Keep treadmill clean by dusting regularly. Be sure to clean the exposed part of the deck on either side of the walking belt and also the side rails. This reduces the build up of foreign material underneath the walking belt. Make sure that shoes are clean. The top of the belt may be cleaned with a wet soapy cloth. Be careful to keep liquid away from inside the motorized treadmill frame or from underneath the belt.

Vacuuming: Always unplug the treadmill from the electrical outlet before removing the motor cover. At least once a year remove the motor cover and vacuum under the motor cover.

Lubricating: This treadmill's walking belt and deck are equipped with a pre-lubricated, low maintenance deck system. The belt/ deck friction may play a major role in the functioning and life of your treadmill, thus requires periodic lubrication. We recommend an annual inspection of deck and running belt by a qualified technician.

We recommend lubrication of the deck according to the following timetable:

Light user (less than 3 hours/ week)	Every 60 days
Medium user (3-5 hours/ week)	Every 45 days
Heavy user (more than 5 hours/ week)	Every 30 days

We suggest you buy lubricating oil with spray nozzle from local distributors or contact our company directly.

For any other maintains please call service professionals for help.

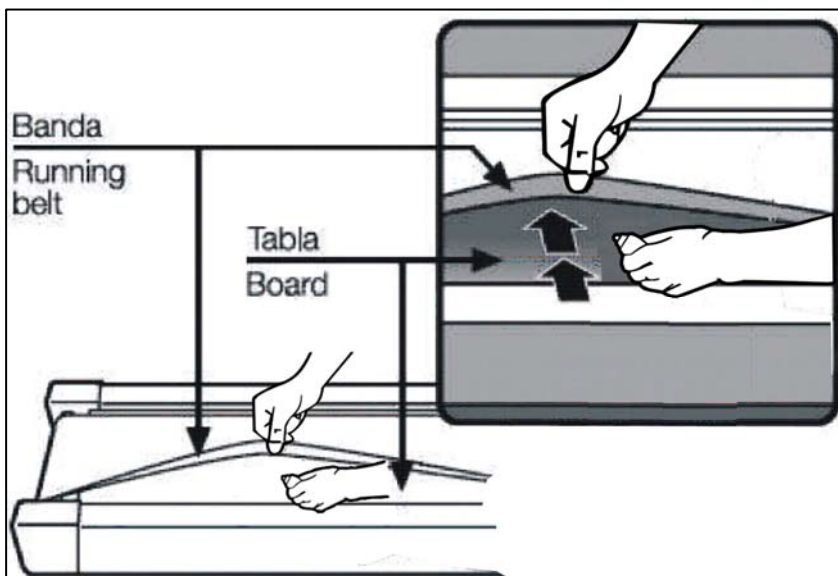

Belt Adjustment

Place treadmill on a level surface. Make treadmill run at approximately 6-8 km/h, observe the running belt deviate condition.

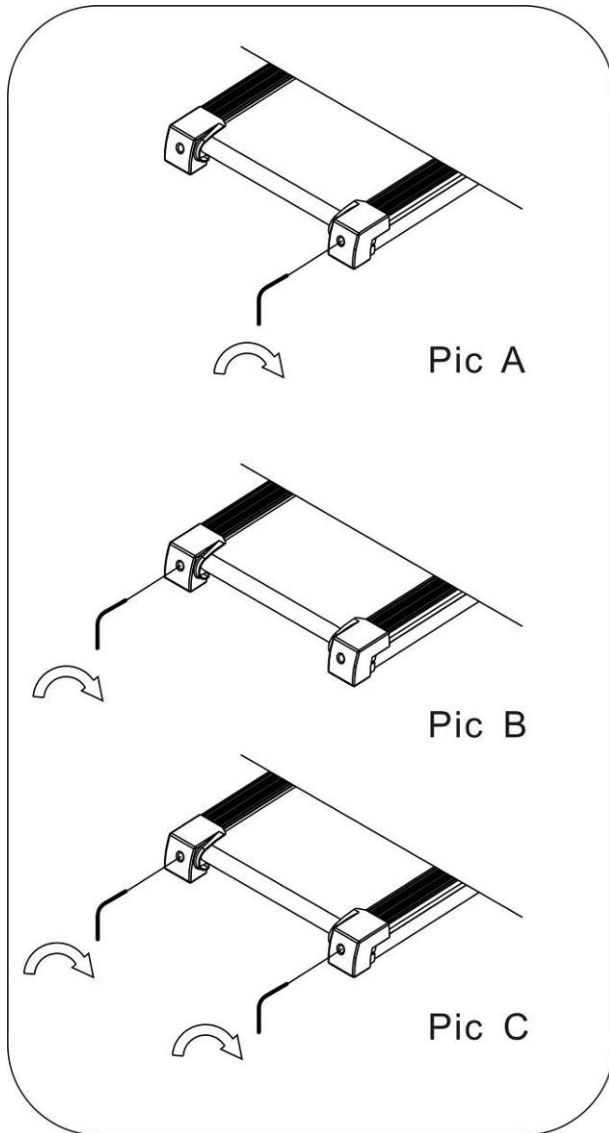

If the belt is drifting to right, unplug safety lock and power switch, and turn the right adjusting bolt 1/4 turn clockwise, re-start treadmill and make it run at above speed, observe the running belt deviate condition for 1-2 minutes. Repeat above steps until the running belt moves back to middle and remains centered.

See picture A

If the belt is drifting to left, unplug the safety lock, turn off power, then turn the left adjusting bolt clockwise by 1 / 4 laps. , a re-start treadmill and make it run at above speed, observe the running belt deviate condition for 1-2 minutes. Repeat above steps until the running belt moves back to middle and remains centered. **See picture B**

Treadmill belt will slightly stretch after a period of use, depends on the frequency it being used, user body weight and woven structure of the belt. If you often feel slippery, you can adjust both adjusting bolt clockwise rotation by 1 / 4 turn. Restart treadmill and stand on the belt to test tightness. If required, repeat the above step once until the belt reaches moderate tightness. If problem persists, call service for help-don't risk over stretch the belt.

See picture C

Exploded drawing

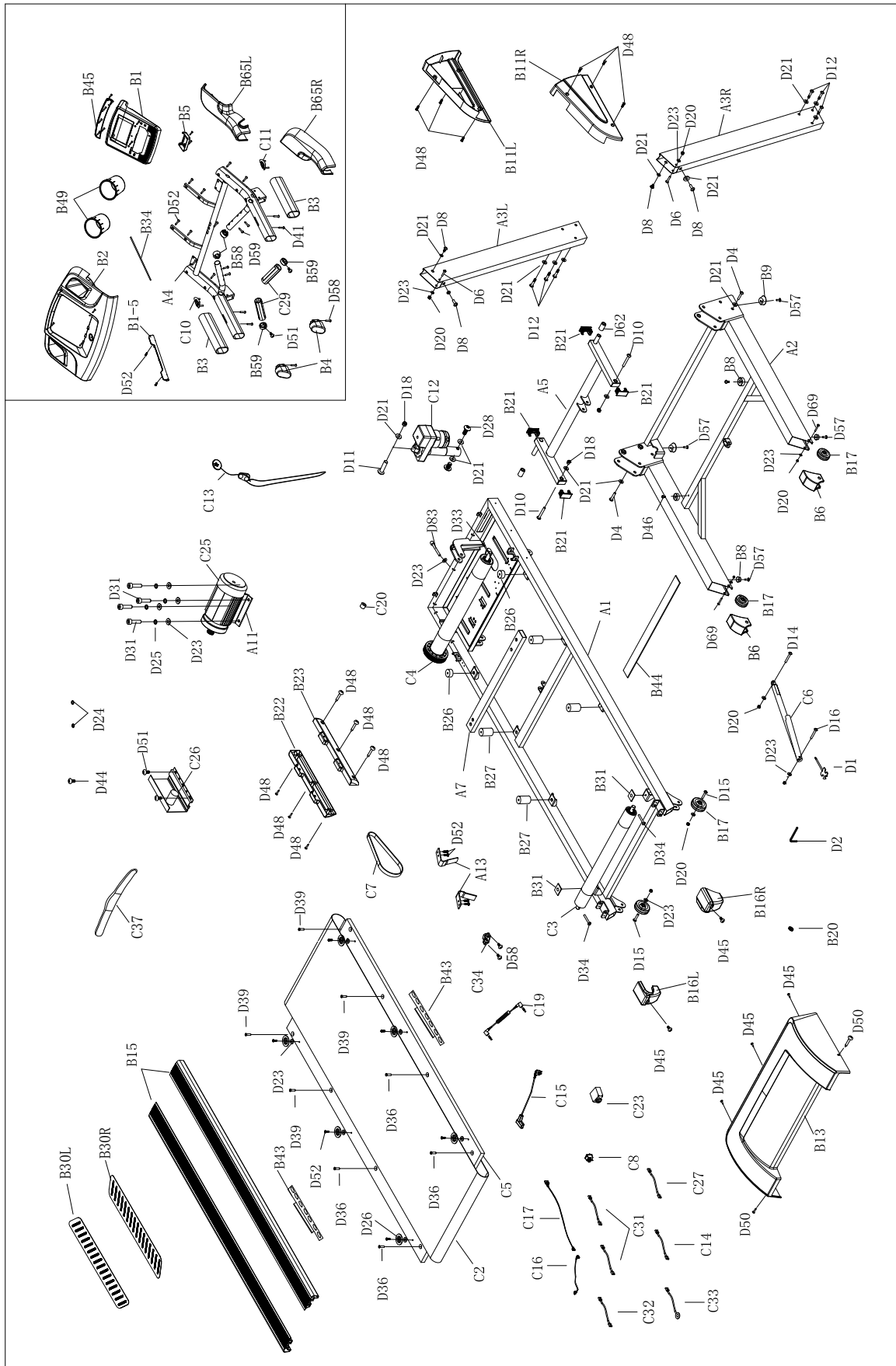

Parts list

A. Welding parts						
No.	Description	Qty		No.	Description	Qty
A1	Main frame	1		A5	Incline bracket	1
A2	Base frame	1		A7	Deck supporting tube	1
A3L	Left upright	1		A11	Motor frame	1
A3R	Right upright	1		A13	Running belt fixing bracket	2
A4	Handrail bracket	1				
B. Plastic parts						
No.	Description	Qty		No.	Description	Qty
B1	Console set	1		B20	Round plug	1
B1-1	Overlay	1		B21	Squared plug	4
B1-2	Membrane key	1		B22	Left motor side cover	1
B1-3	Console	1		B23	Right motor side cover	1
B1-5	iPad holder	1		B26	Deck cushion	2
B2	Console panel	1		B27	Cushion set	4
B3	Protecting foam	2		B30L	Left anti-slippery pad	1
B4	Handrail plug	2		B30R	Right anti-slippery pad	1
B5	Console back cover 1	1		B31	Rubber pad	2
B6	Transporting wheel cover	2		B34	EVA pad (for iPad holder)	1
B8	Flat feet pad	4		B43	PVC cushion	2
B9	U-shape feet pad	2		B44	EVA pad	1
B11L	Left side cover	1		B45	Console back cover 2	1
B11R	Right side cover	1		B49	Bottle holder	2
B13	Motor upper cover	1		B58	Handrail cover 1	2
B15	Side rail	2		B59	Handrail cover 2	2
B16L	Left end cap	1		B65L	Left console side cover	1
B16R	Right end cap	1		B65R	Right console side cover	1
B17	Adjusting wheel	4				
C. Electric parts						
No.	Description	Qty		No.	Description	Qty
C2	Running belt	1		C17	Lower wire	1
C3	Rear roller	1		C19	MP3 cable	1

C4	Front roller	1		C20	Magnetic ring	1
C5	Running deck	1		C23	Overload protector	1
C6	Cylinder	1		C25	AC motor	1
C7	Drive belt	1		C26	Inverter	1
C8	Power switch	1		C27	Single cord (black)	1
C10	Quick buttons on left handrail	1		C29	Han pulse sensor	2
C11	Quick buttons on right handrail	1		C31	Short single cord (red)	2
C12	Incline motor	1		C32	Short single cord (black)	1
C13	Safety key	1		C33	Grounding cable	1
C14	Single cord (red)	1		C34	3-pin outlet	1
C15	Power cable	1		C37	Chest belt	1
C16	Upper wire	1				

D. Hardware

No.	Description	Qty	No.	Description	Qty
D1	Screw driver 13-15-17	1	D31	Hex head round bolt M8X20	4
D2	Allen wrench T6	1	D33	Hex head round bolt M8X55	1
D4	Round head hex bolt M10X65	2	D34	Hex head round bolt M8X60	2
D6	Round head hex bolt M8X50	2	D36	Cross head bolt M6X25	4
D8	Round head hex bolt M10X15	4	D39	Cross head bolt M6X40	4
D10	Round head hex bolt M10X45	2	D41	Cross head self-tapping bolt 4.2X70	4
D11	Round head hex bolt M10X50	1	D44	Cross head bolt M5X12, washer	1
D12	Round head hex bolt M10X55	6	D45	Cross head bolt M5X15, washer	5
D14	Round head hex bolt M8X30	1	D46	Cross head bolt M5X20, washer	2
D15	Round head hex bolt M8X40	2	D48	Cross head self-tapping bolt ST4.2X19, washer	12
D16	Round head hex bolt M8X45	1	D50	Cross head self-tapping bolt ST4.2X25, washer	2
D18	Nylon nut M10	3	D51	Cross head bolt M5X8	4
D20	Nylon nut M8	8	D52	Cross head self-tapping bolt ST4.2X16	34
D21	Flat washer M10	17	D57	Cross head self-tapping bolt ST4.2X25	4
D23	Flat washer M8	19	D58	Cross head self-tapping bolt ST3.5X16	4
D24	Spring washer M5	2	D59	Cross head self-tapping bolt ST2.9X25	4
D25	Spring washer M8	4	D62	Incline rotating tube	2
D26	Arc washer	6	D69	Round head hex bolt M8X55	2
D28	Hex head round bolt M10X20	2	D83	Round head hex bolt M8X45	1

Error code and trouble shooting

Error Code	Fault	Symptoms and Trouble shooting
E1	Communication abnormal: The inverter and console has abnormal communication	<ol style="list-style-type: none"> 1. Check the connecting wire between console and inverter if connection is good. 2. When wire is in good condition, change the inverter to see if problem solved. 3. When wire is in good condition, change the console to see if problem solved.
E2	Inverter is over-heated	<ol style="list-style-type: none"> 1. Check if the problem still exists after un-plug power for over 20 minutes. 2. Check if the fan is too dirty and function well. Clean the fan and try again. 3. Change inverter if the above solutions can't work.
E3	Low voltage input on inverter	<ol style="list-style-type: none"> 1. Check if the problem still exists after un-plug power for over 20 minutes. 2. Check if power outlet supplies low voltage. Change an outlet to see if it's solved. 3. Change inverter if the above solutions can't work.
E4	Incline calibration	<ol style="list-style-type: none"> 1. Check if the motor wires are all connected well. 2. Check if wires between motor and inverter are connected correctly under corresponding labels. 3. Change incline motor if above solutions can't work.
E5	Overcurrent protection	<ol style="list-style-type: none"> 1. Check if the problem still exists after un-plug power for over 20 minutes. 2. Check if front or rear roller is damaged. 3. Check if lubrication needs to be applied on running belt or running board. 4. Change inverter if above solutions can't work.
E7	Overload protection	
E9	Incline problem	<ol style="list-style-type: none"> 1. Check if sensor of incline motor is connected well. 2. Check if problem is solved after changing inverter or incline motor
Er	Inverter problem	<ol style="list-style-type: none"> 1. Check if the problem still exists after un-plug power for over 20 minutes. 2. Check if wires are all connected well. 3. Change inverter if the above solutions can't work.
—	Console cannot detect the signal of safety key	<ol style="list-style-type: none"> 1. Check if safety key is placed in correct position. 2. Check if magnet on safety key is damaged. 3. When above methods do not work, change a safety key to see if problem is solved.
Console shows as "Blank"	/	<ol style="list-style-type: none"> 1. Check if power cable connects well. 2. Check if power switch is on. 3. Check if fuse is burnt down or not. 4. Check if wire connecting well console and controller is in good condition or connects well. 5. When above methods do not work, change console or inverter to see if problem is solved.