

Orbit SS55C

SS55C



- **Warranty**
- **Assembly**
- **Parts**

**TOOL REQUIRED
FOR ASSEMBLY**
Adjustable Wrench
Pliers
Hammer

Owner's manual SS 55C

CAUTION: 1. Weight on this product should not exceed 110kgs
2.Exercise of a strenuous nature, as is customarily done on this equipment, should not be undertaken without first consulting a physician. No specific health claims are made or implied as they relate to the equipment. Measurements made by the equipment are believed to be accurate, but only The measurements of your physician should be relied upon.

IMPORTANT: Read all Instructions carefully before using this product. Retain this product owner' manual for future reference.

Contents	1
Safety Caution	2-3
Assembly instruction	4-6
Operation guide	7-19
How to fold and move	20
Suggested stretches	21-22
Maintenance	23-24
Exploded drawing	25
Part list	26
TROUBLE SHOOTING	27

SAFETY CAUTIONS

When using this product, basic precautions should always be followed, including the following:

Please read the instruction carefully before starting to use this product.

Danger – To reduce the risk of electric shock:

1. Always unplug this product from the electrical outlet immediately after using and before cleaning.

Warning – To reduce the risk of burns, fire, electric shock, or physical injury:

1. The product should never be left unattended while plugged in. Unplug the product from the outlet when not in use.
2. Close supervision is necessary when this product is used by or near children, invalids, or disabled persons.
3. Be sure to use the product only for its intended use as described in this manual. Do not use any attachment not recommended by the manufacturer in order to avoid any danger or accidents.
4. Never operate the product if it has a damaged cord or plug, if it is not working properly, if it has been damaged, or dropped into water. Please return the product to the service center of seller for examination and repair.
5. Do not carry this product by the supply cord or use the cord as a handle.
6. Keep the cord away from hot surfaces or ground.
7. Never operate the product with the air vents blocked. Keep the air vents free of lint, hair, etc.
8. Never drop or insert any objects into any openings.
9. Do not use or operate outdoors.
10. Do not operate where aerosol (spray) products are being used or where oxygen is thin.
11. Before turning the product power off, turn all controls to the off position then remove the plug from the outlet.
12. Connect the product to a properly grounded outlet only.
13. If the treadmill is foldable, when user finishes using the treadmill, the elevation needs to be back to original position.
14. When user is using the treadmill, it cannot be folded at the same time.
15. Keep a safety zone of 2000mm x 1000mm away from the treadmill.
16. This machine is only intended for household use.
17. For the treadmill with folding function and electric elevation, be sure that the elevation is 0 before folding (To avoid interference of the components).
18. Stop using the treadmill if you feel faint, dizzy, or short of breath.
19. Wear appropriate exercise clothes when using the treadmill. Do not wear loose clothes that could become caught in the treadmill. Athletic support clothes are recommended for both men and women. Always wear athletic shoes. Never use the treadmill with bare feet, wearing only stockings, or in sandals.

SAFETY CAUTIONS

GROUNDING INSTRUCTIONS

The products must be grounded first. If malfunction or breakdown occurs, grounding will provide a path of least resistance for electric current to reduce the risk of electric shock.

The product is equipped with a cord having an equipment-grounding conductor and a grounding plug.

The plug must be plugged into an appropriate outlet that is properly installed and grounded in accordance with all local codes and ordinances.

Danger – Improper connection of the equipment-grounding conductor can result in a risk of electric shock. Check with a qualified electrician or serviceman if you are in doubt as to whether the products are properly grounded. Do not modify the plug provided with the product – if it will not fit the outlet, have a proper outlet install by a qualified electrician.

The products is for use on nominal 220-240 volt and has a grounding plug that looks like the plug illustrated in the figure . Make sure that the product is connected to an outlet having the same configuration as the plug.

There is no need to use any adapter for this product.

Figure
Grounding methods

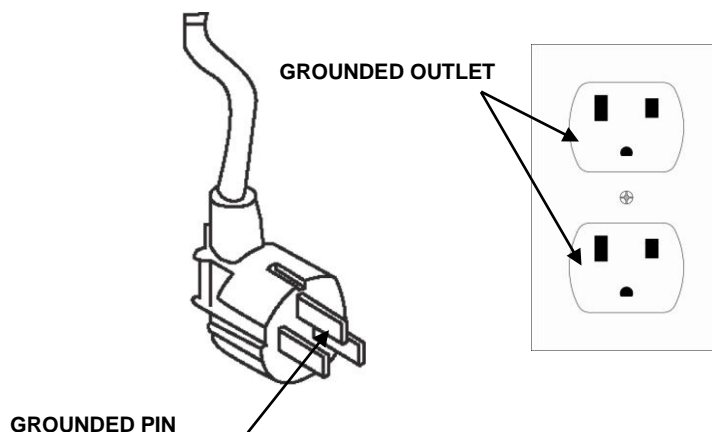

OPEN THE BOX YOU CAN FIND THE ALL PARTS AS BELOW

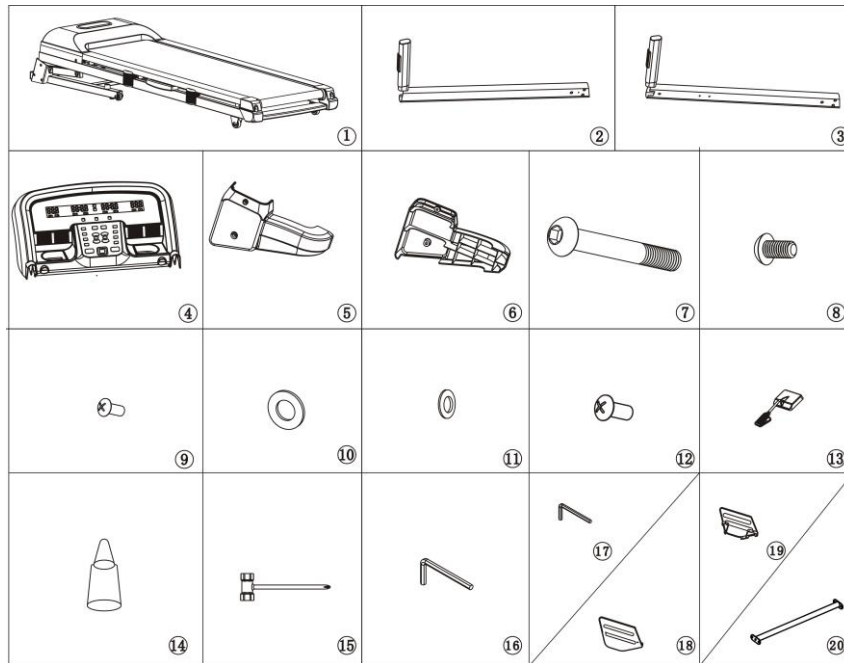

Part list					
No.	Description	Quantity	No.	Description	Quantit
1	MAIN FRAME	1PC	11	FLAT WASHER M8	8PCS
2	LEFT UPRIGHT	1PC	12	SCREW M6*10MM	4PCS
3	RIGHT UPRIGHT	1PC	13	SAFETY KEY	1PC
4	CONSOLE SET	1SET	14	LUBRICATION OIL	1PC
5	BASE COVER-L	1PC	15	SCREWDRIVER	1PC
6	BASE COVER-R	1PC	16	WRENCH 6MM	1PC
7	BOLT M10*50MM	6PCS	17	WRENCH 5MM	1PC
8	BOLT M8*15MM	8PCS	18	FRAME WHEEL COVER-L	1PC
9	SCREW M5*12MM	4PCS	19	FRAME WHEEL COVER-R	1PC
10	FLAT WASHER M10	6PCS	20	Connecting tube	1PC

ASSEMBLY INSTRUCTIONS

STEP 1

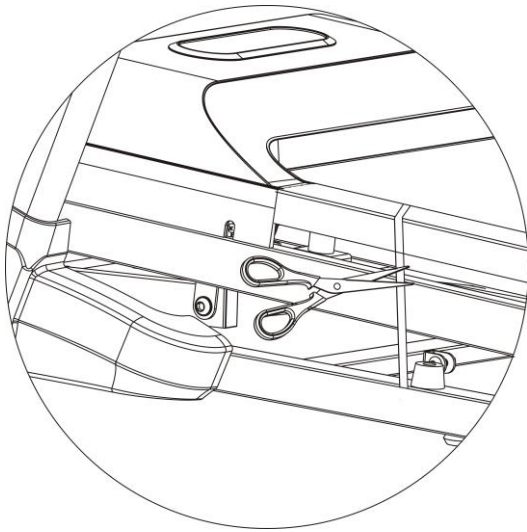

1. Please note that this treadmill need at least 2 people to finish assembly.
2. Open the carton box, and take out all the protection foam and assembly parts.
3. As the photo shows, take out the running deck from the box, lay it on the flat floor, and then cut the belt.

! DANGER!

Do not cut the zip ties before moving the treadmill out from the carton!
Do not cut the zip ties until put the treadmill base on the flat floor!
Failure to do so could result in body injury!

STEP 2

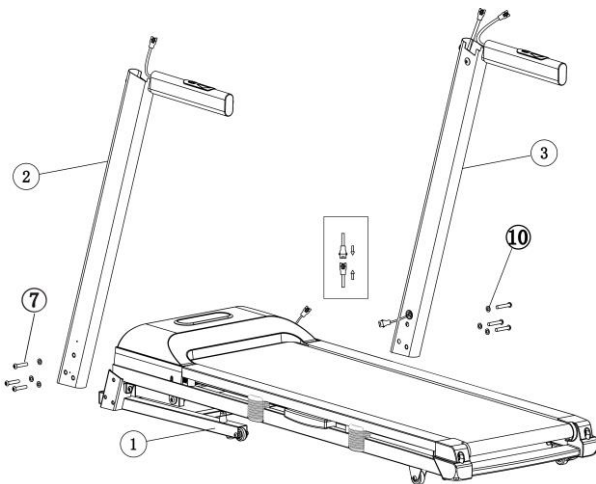

1. Lift up the left upright(2) and right upright(3), and then use the #6 wrench(16) to fasten each upright onto the base with each 3pcs of bolt M10*50mm(7) and flat washer M10(10)
2. Do not tightly fasten all the bolts and screws at this step.

STEP 3

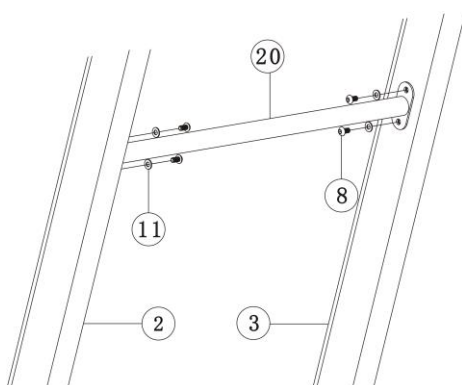

1. Use the #5 Wrench(17) to fasten the cross bar onto the left and right uprights(2,3) with each 4p cs bolt M8*15(8) and flat washer M8(11)

ASSEMBLY INSTRUCTIONS

STEP 3

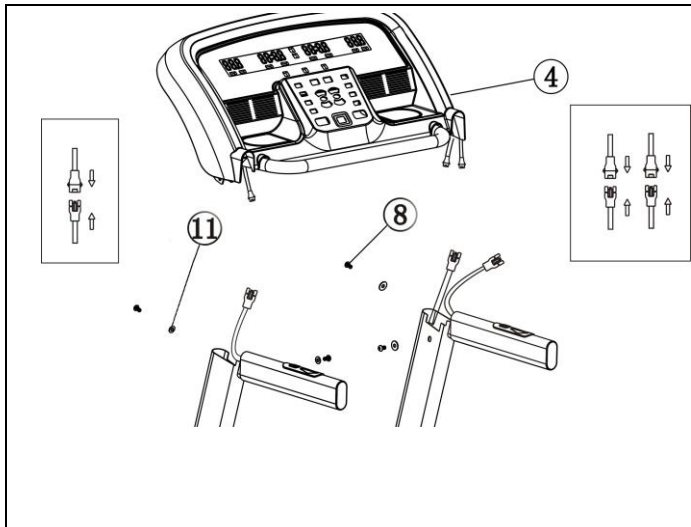

1. Connect the signal wire from console to the signal wire of the left and right uprights.
2. Use the 5# wrench (17) to fasten the console to the left and right upright with each 4pcs M8x15 bolts (8) and flat washers M8(11)
Pay attention to the connection of the cable, a wrong connection or rough operation would cause damage of the connector
3. Tightly fasten all the bolts at step 2 and step 3

STEP 4

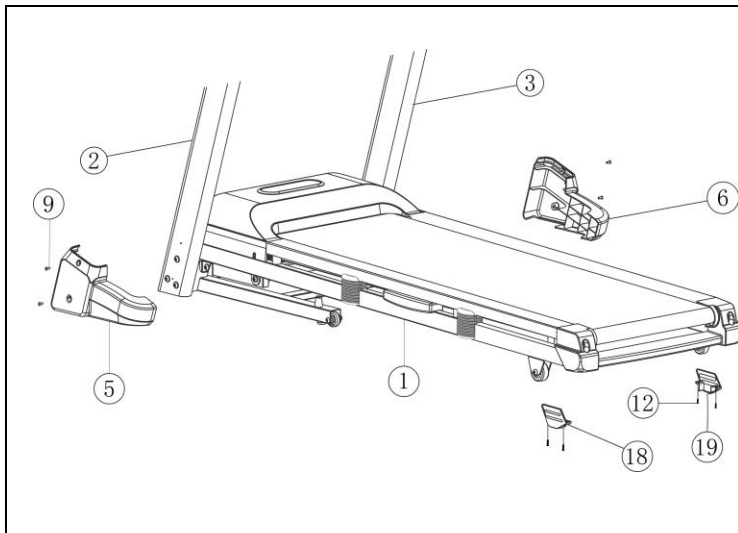

1. Use the screwdriver(15) to fasten the left base cover(5) and right base cover(6) onto the left and right uprights with 4pcs bolt M5*12(9).
2. Use the screwdriver(15) to fasten the left frame wheel cover(18) and right frame wheel cover(19) onto the main frame(1) with 4pcs of bolt M6*10.



NOTE: For your safety and comfort, please check if all screws are fastened.
Congratulation!
A brand new motorized treadmill has been successful assembled!

OPERATION GUIDE

GENERAL SAFETY TIPS

- A.** Practice mounting and dismounting your treadmill before beginning your workout.
- B.** Attach the Safety Key to the Computer (the treadmill will not operate without the Safety Key). Clip the other end of the Safety Key to your clothing before exercising to ensure the treadmill will stop if the user accidentally walks off the Treadmill.
- C.** If the user falls off the Treadmill, the Safety Key will come off the Computer and the treadmill will stop at once to avoid further injury.
- D.** Do not stand on the Walking Belt while starting the Treadmill. Straddle the Belt and stand on the plastic Foot Rails.
- E.** The Treadmill will start at 1.0KM/H after countdown. If you are a new user, stay at a slow speed and hold onto the Hand Grips until you become comfortable.

QUICK REFERENCE GUIDE

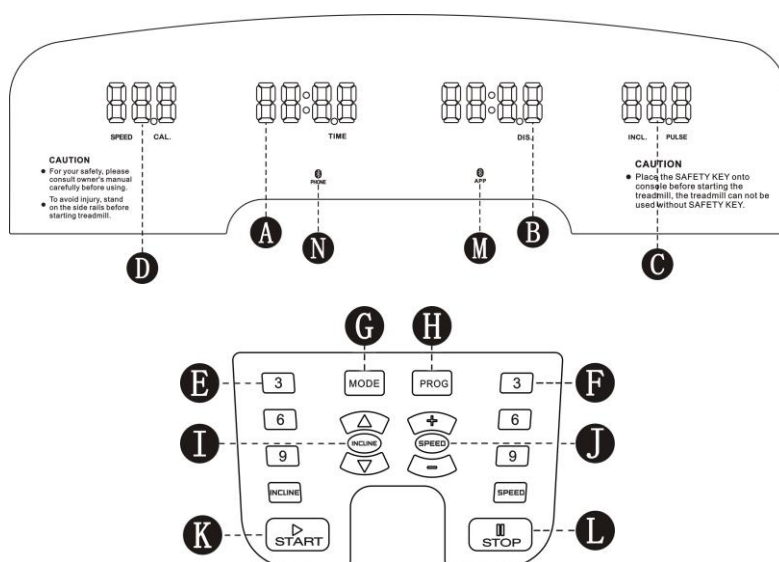

A	TIME WINDOW	F	QUICK SPEED BUTTON	K	START BUTTON
B	DISTANCE WINDOW	G	MODE BUTTON	L	STOP BUTTON
C	INCLINE WINDOW	H	PROGRAM BUTTON	M	APP FIGURE
D	SPEED WINDOW	I	INCLINE \wedge/\vee BUTTON	N	PHONE FIGURE
E	QUICK INCLINE BUTTON	J	SPEED +/- BUTTON		

DISPLAY FUNCTION

TIME: Accumulates total workout time from 0:00 to 99:00 minutes.

PULSE: When pulse signal is detected by grasping both stainless steel pick-ups on front handrails, it will display your current heart rate in beats per minute from 50 to 200..

INCLINE: Displays the current deck incline from starting at level 1 to 15.

SPEED: Displays the current belt speed from starting at 1.0KM/H to max speed.

CALORIE: Accumulates calorie consumption during exercise. Max. Value is 990 KCAL.

DISTANCE: Accumulates total workout distance from 1.00 to 99.0 kilometers by count-up.

Accumulates total workout distance from 99.0 to 1.00 kilometers by count-down.

GETTING STARTED

NOTES:

1. Check to make sure nothing is on or will hinder the movement of the treadmill.
2. Plug in the power cord and turn the treadmill ON.
3. Stand on the foot rails of the treadmill.
4. Attach the safety key clip to part of your clothing.
5. Put the safety key into the safety key hole in the console, and then the treadmill will be on start/ready status.
6. You have two options to start your workout:

A. QUICK START

Simply press the START button to begin working out.

B. SELECT A PROGRAM

Select manual program by pressing MODE button or pressing PROGRAM buttons to enter manual program, 8 training goals or 3 user programs.

QUICK-START OPERATION

STEP 1: Attach the Safety key to wake display up; the treadmill then will be on start/ready status.

STEP 2: Press the START button to begin belt movement after count-down. Use the SPEED +/- or QUICK SPEED buttons to adjust the desired speed at any time during training; use the INCLINE \wedge/\vee or QUICK INCLINE buttons to adjust the incline at any time during training.

STEP 3: To get a pulse reading, simply grasp stainless steel pick-ups on handrails. It may take a few seconds for the display to reach the actual number. The pulse rate will be displayed on PULSE window.

STEP 4: During quick-start operation, TIME, CALORIE and DISTANCE will count up.

MANUAL PROGRAMS OPERATION

NOTES: Under this program, one of DISTANCE, CALORIE and TIME can be set count-down for your workout, the others will count up during your workout, after one count-down reach zero, program will be ended and stop the belt movement, if you need to continue, press the START button to begin belt movement after count-down.

STEP 1: Attach the Safety key to wake display up; the treadmill then will be on start/ready status.

STEP 2: Press MODE button, the TIME window will display 30:00, press SPEED +/- button to set count-down TIME from 5:00 minutes to 99:00 minutes.

If you do not like to set TIME for count-down and pass to others, press MODE again, the DIST window will display 1.0, you can set count-down DISTANCE from 1.0KM - 99.0KM.

If you do not like to set DISTANCE for count-down and pass to others, press MODE again, the CAL. window will display 50, you can set count-down CALORIE from 20 KCAL to 990 KCAL.

STEP 3: After finishing setting count-down for your workout, press START to begin belt movement after count-down.

OPERATION GUIDE

STEP 4: During the program you can adjust the speed and incline by pressing SPEED +/- and INCLINE ^/∇ buttons, or QUICK SPEED and QUICK INCLINE buttons to jump directly to a setting.

STEP 5: Press STOP button to stop your workout or pull safety key away from its position to shut down the computer.

PRESET PROGRAMS OPERATION

NOTES:

All the preset programs are made up with 18 time-based segments; the speed and incline are preset on each segment. The elapse time of 18 segments on each program will be automatically arranged according to the time you set for your workout time. There are 64 preset programs for 8 different training goals, and 8 different intensity levels on each training goals.

STEP 1: Attach the Safety key to wake display up; the treadmill then will be on start/ready status.

STEP 2: Press PROGRAM button to scroll through the 8 training goals, and BODY FAT function. A training goal will be selected once you press PROGRAM button. After selecting a training goal, press MODE button to select a intensity from L1 to L8. After selecting a intensity, then press SPEED +/- buttons to modify the elapsing time. The pre-set elapsing time of each program is 30:00 minutes, and it can be set from 5:00 to 99:00 minutes.

STEP 3: After modifying the elapsing time, press START button to accept and begin your workout.

STEP 4: During procession of program you can adjust the SPEED & INCLINE by pressing SPEED +/- and INCLINE ^/∇ buttons, or use QUICK SPEED and QUICK INCLINE buttons

to jump directly to a setting. However, the SPEED and INCLINE you adjust will only be effective on the ongoing segment, after the segment finished, the SPEED and INCLINE will process with preset values.

STEP 5: Press STOP button to stop your workout or pull safety key away from its position to shut down the computer.

USING THE PULSE FUNCTION

The PULSE Window on your Computer works in conjunction with the Pulse Sensors on both handrails. When you are ready to read your pulse:

1. Place both hands firmly on the Pulse Sensors. For the most accurate reading, it is important to use both hands.
2. Your estimated heart rate will display in the PULSE window approximately 5 seconds after you hold the Pulse Sensors.
3. This estimate is not exact and persons with medical conditions and/or a specific need for accurate heart rate monitoring should not rely on the estimations provided.

USER PROGRAM

This program is for user to edit a personal program; the speed and incline of each segment can be edited according as personal's desire. There are 18 segments on this program for user to edit workout program.

Once the program is set, it will be stored on the computer, the computer will proceed the program by pressing START/STOP button. There are totally 3 user program can be edited.

If you want to re-edit the program, just follow the steps described as bellow.

STEP 1: Attach the Safety key to wake display up; the treadmill then will be on start/ready status, keep pressing PROG button until the distance window display U-1, then the TIME window display 30:00, press SPEED+/- to set the program time.

STEP 2: Press MODE button to set segment 01, press INCLINE \wedge/\vee to set incline and press SPEED+/- to set speed on this segment. After finish setting segment 01, press MODE button to set all other 2-18 segments.

STEP 3: After finish setting all 18 segments, the program will be stored, and then press START button to load this program.

BODY FAT SCALE

This function is to estimate your body fat according to the basic information of you body condition.

This estimate is not exact and persons with medical conditions and/or a specific need for accurate body fat value should not rely on the estimations provided.

STEP 1: Press PROGRAM button repeatedly, on the "11" time pressing PROGRAM button, the TIME window will display FAT. Press MODE button to set the relative parameters: GENDER, AGE, HEIGHT and WEIGHT.

STEP 2: After entering BODY FAT function by pressing MODE button, the INCLINE window will display F1, the DIST window will display 1, it represents GENDER, press SPEED +/- button to set gender from 1 - 2, 1 represents MALE, 2 represents FEMALE. Then press MODE button to go to next step.

STEP 3: After pressing MODE button, the INCLINE window will display F2, the DIST window will display 25, it represents AGE, press SPEED +/- button to set age from 10-99. Then press MODE button to go to next step.

STEP 4: After pressing MODE button, the INCLINE window will display F3, the DIST window will display 170, it represents HEIGHT, press SPEED +/- button to set height from 100CM-200CM. Then press MODE button to go to next step.

STEP 5: After pressing MODE button, the INCLINE window will display F4, the DIST window will display 70, it represents WEIGHT, press SPEED +/- button to set weight from 20KG-150KG. Then press MODE button to go to next step.

STEP 6: After finished setting all the necessary information of your body condition, press MODE button again, the INCLINE window will then display F5, the DIST window will display "----", it means the computer start to work for calculating, then hold the pulse sensor on handrail with both of your hands, around 8 seconds after, the body fat result will be displayed on INCLINE window.

BODY FAT CHART

The result that given by body fat scale can be a reference of body condition, check your body condition according to the left chart with the result you get from the treadmill.

OPERATION GUIDE

Body condition	Result
Fat	BMI > 30
Overweight	26 < BMI < 30
Fit	19 < BMI < 25
Thin	BMI < 19

BLUETOOTH MUSIC PLAYER

The treadmill have the bluetooth function, then connect the smart phone as follow steps:

STEP1: Turn on the Bluetooth of the smart phone, search the device, and click to connect the devices when RUN MUSIC appears.

STEP2: After the connection, the voice of smart phone will be played by the speaker on the console.

BLUETOOTH APP FUNCTION

1.FitShow Download



Scan QR code to download the APP directly, or download and install over the application stores by search 'FitShow'.

2.Application Operation

2.1 User register/signup and login

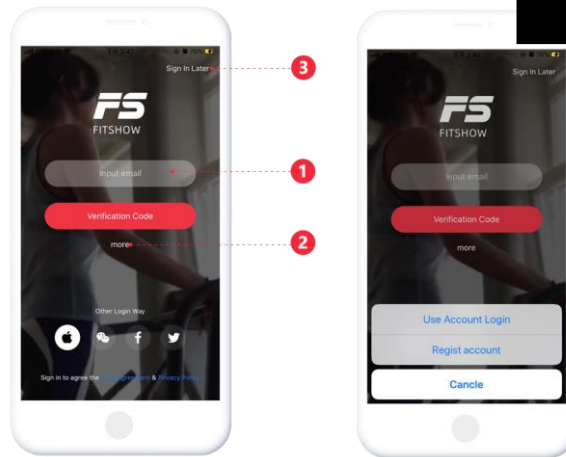

【1】 : Generate a verification code to log in directly

【2】 : Tap 'More' -> Password Login to input the existing account and password

【3】 : Log in as a guest

2.2 Device Connection

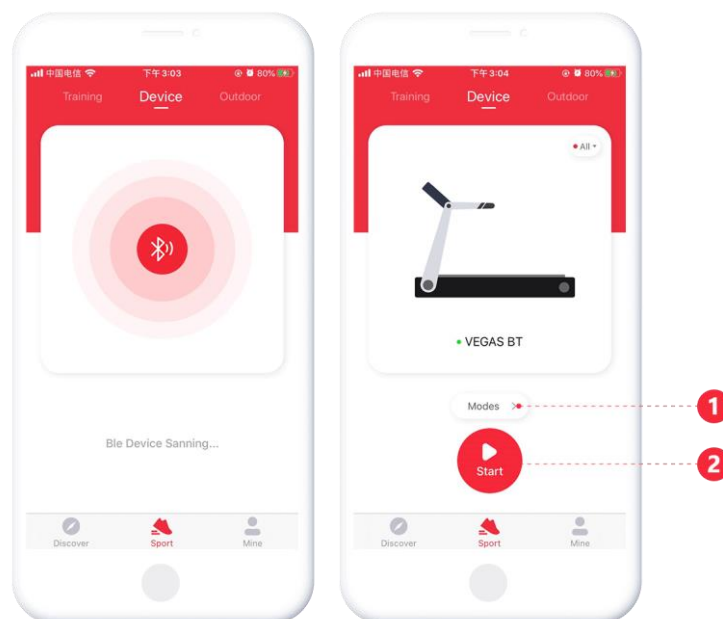

Before connecting the device, please make sure the system Bluetooth and GPS(Andriod8.0 and above required) are ON status. Then go to [Sports - Devices] page, get the devices nearby via Bluetooth search.

Note:

1. Please do not bind devices by the phone Bluetooth list which will disable the APP.
2. If the device is powered by battery, please run the device one or two to activate the device then connect APP.

2.3 Model Selection

OPERATION GUIDE

Tap a model **【1】** to enter the corresponding sports model. And connect the desired device by the nearby devices list **【2】**.

2.4 Sports Control

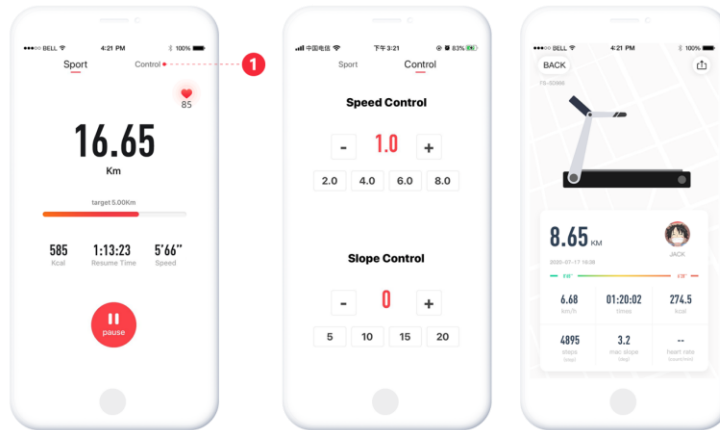

Start the treadmill to enter the sports car table, and control the sports by the **【1】** control options. The motion data is generated synchronously after the sports.

2.5 Sports Training

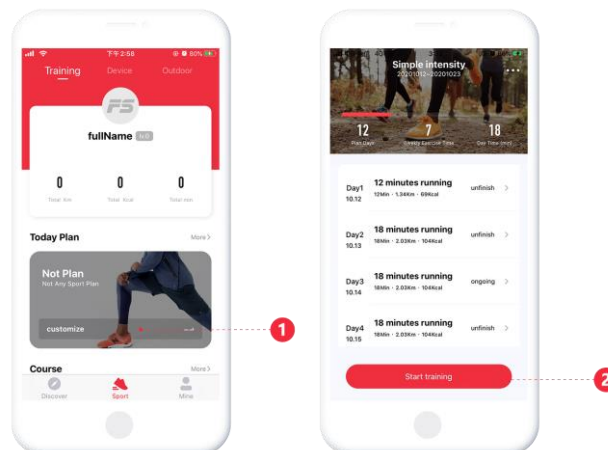

Enter [SPorts - Training] page, make a daily sport plan by the **【1】**. Once the plan is created, tap **【2】** to start the plan.

2.6 Outdoor Sports

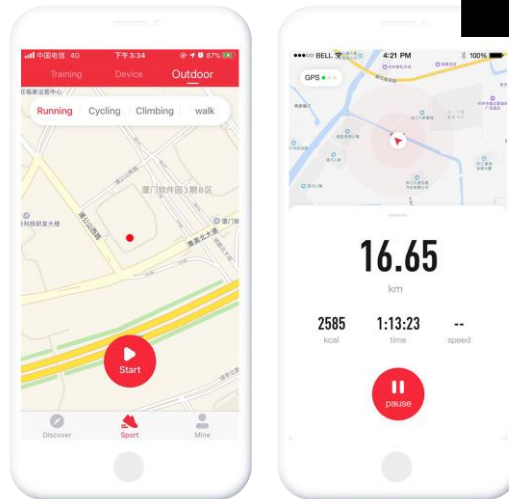

Enter [Sports - OutDoor] page to start a related outdoor sports model.

2.7 Discover

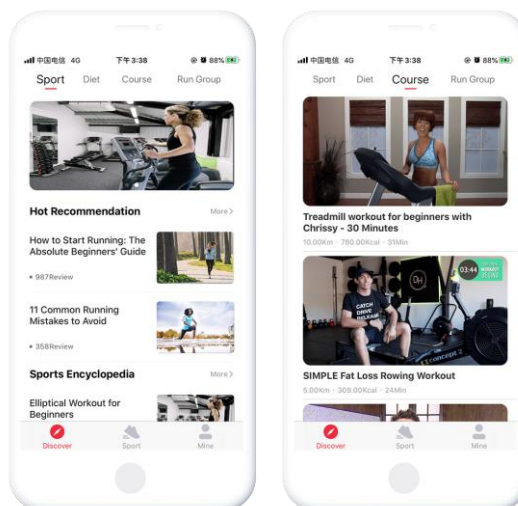

Enter [Discover] page to find more sports, diet, course, and other wonderful content recommendations.

2.8 My Center

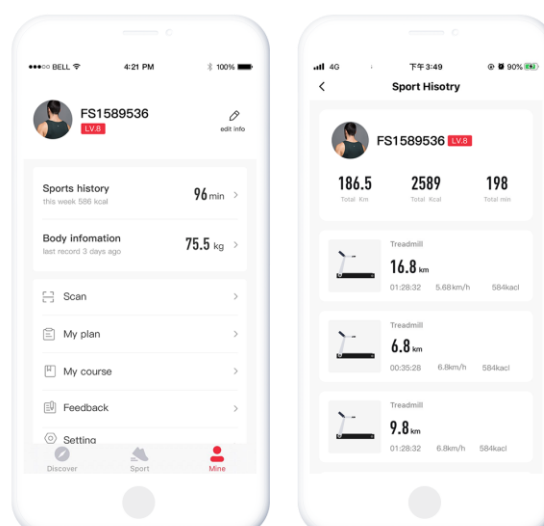

OPERATION GUIDE

Enter [Mine] page to view the sports data record, edit profile, change system setting, and so on

3. The Third-Party Application

3.1 Kinomap

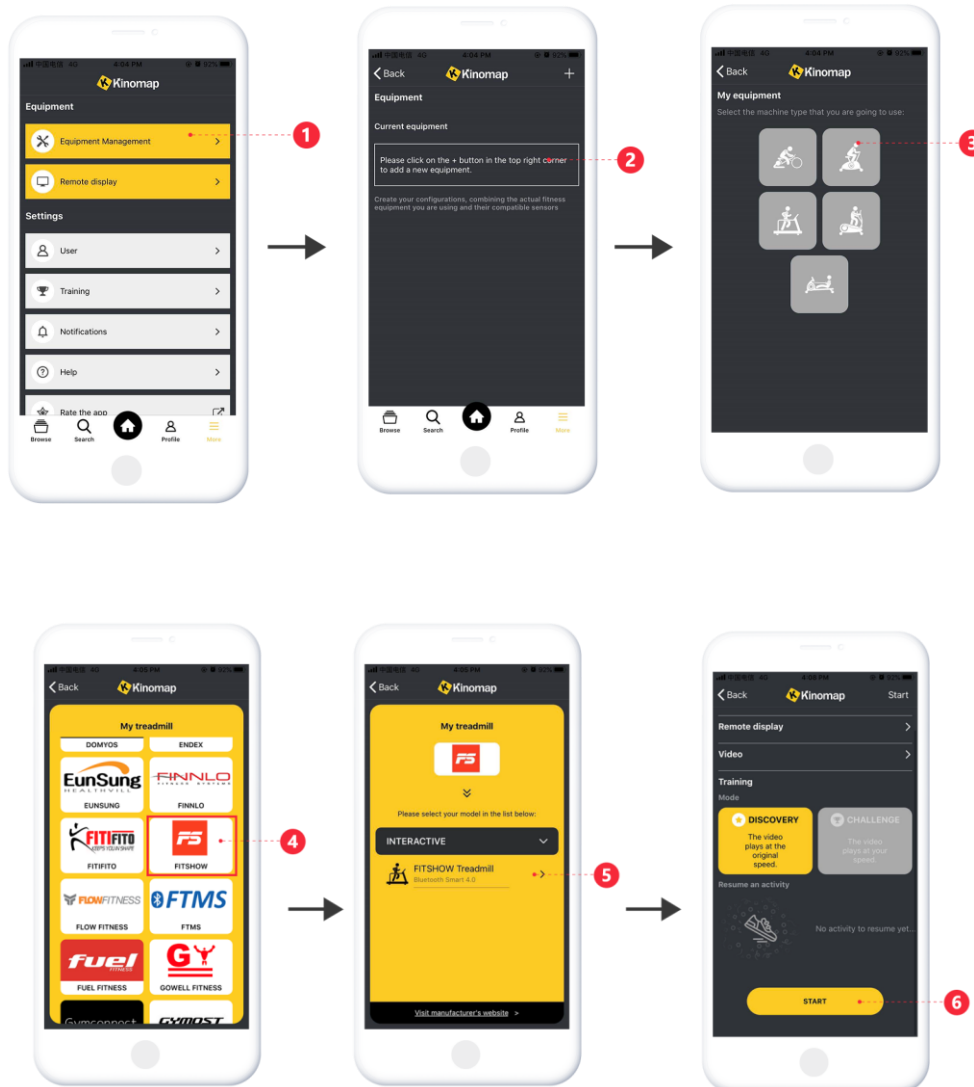

Search, download, and install Kinomap over the App Store.

【1】 Enter Kinomap to select [More] page;

【2】 Select to add more fitness equipment;

【3】 Select the desired device type;

【4】 Tap FitShow entrance;

【5】 Tap the matching devices like 'Fs-XXXX' to bind Find related videos to start sports.

【6】 Find related videos to start sports

3.2 ZWIFT

OPERATION GUIDE

Search, download, and install ZWIFT over the App Store.

【1】 Enter ZWIFT to register an account;

【2】 Login account to select the paired riding or running equipment;

【3】 Pair device successfully, tap OK to start sport;

【4】 For riding equipment, start riding directly. For running equipment, need to press the start button to start running.

OPERATION GUIDE

PRESET PROGRAM CHART

P1. WEIGHT LOST

SPEED CHANGES		1	2	3	4	5	6	7	8	9	10	11	12	13	14	15	16	17	18
Level 1	SPEED(KM/H)	1	2	2	3	3	3	4	5	6	6	7	6	5	4	4	3	2	2
Level 2	SPEED(KM/H)	1	2	2	3	4	4	5	6	8	8	10	8	8	5	5	3	2	2
Level 3	SPEED(KM/H)	1	2	3	4	5	5	6	8	9	10	12	10	8	7	6	4	3	2
Level 4	SPEED(KM/H)	1	2	3	4	6	7	8	10	11	12	13	11	10	8	7	5	4	2
Level 5	SPEED(KM/H)	2	3	4	5	7	7	8	10	12	14	14	13	12	10	9	6	4	2
Level 6	SPEED(KM/H)	2	3	4	5	7	9	10	12	13	14	14	13	12	10	9	6	5	3
Level 7	SPEED(KM/H)	2	3	5	6	8	9	10	12	13	14	15	13	12	10	9	6	6	3
Level 8	SPEED(KM/H)	2	3	5	6	8	10	12	14	14	15	15	14	13	11	9	7	6	3

P2. CARDIO TRAIN

SPEED & INCLINE CHANGES		1	2	3	4	5	6	7	8	9	10	11	12	13	14	15	16	17	18
Level 1	ELEVATION	1	1	2	3	4	5	6	7	7	8	8	7	7	5	4	2	1	1
	SPEED(KM/H)	1	1	2	2	3	4	5	6	6	7	7	6	6	4	3	2	1	1
Level 2	ELEVATION	1	2	3	4	5	6	7	8	8	9	9	8	8	6	5	3	2	1
	SPEED(KM/H)	1	2	2	3	4	5	6	7	7	8	8	7	7	5	4	2	2	1
Level 3	ELEVATION	1	2	4	5	6	7	8	9	9	10	10	9	9	7	6	4	2	1
	SPEED(KM/H)	1	2	3	4	5	6	7	8	8	9	9	8	8	6	5	3	2	1
Level 4	ELEVATION	2	3	5	6	7	8	9	10	10	11	11	10	10	8	7	5	3	2
	SPEED(KM/H)	2	2	4	5	6	7	8	9	9	10	10	9	9	7	6	4	2	2
Level 5	ELEVATION	2	4	6	7	8	9	10	11	11	12	12	11	11	9	8	6	4	2
	SPEED(KM/H)	2	3	5	6	7	8	9	10	10	11	11	10	10	8	7	5	3	2
Level 6	ELEVATION	3	5	7	8	9	10	11	12	12	13	13	12	12	10	9	7	5	3
	SPEED(KM/H)	2	4	6	7	8	9	10	11	11	12	12	11	11	9	8	6	4	2
Level 7	ELEVATION	4	6	8	9	10	11	12	13	13	14	14	13	13	11	10	8	6	4
	SPEED(KM/H)	3	5	7	8	9	10	11	12	12	13	13	12	12	10	9	7	5	3
Level 8	ELEVATION	5	7	9	10	11	12	13	14	14	15	15	14	14	12	11	9	7	5
	SPEED(KM/H)	4	6	8	9	10	11	12	13	13	14	14	13	13	11	10	8	6	4

P4. POWER WALK

SPEED CHANGES		1	2	3	4	5	6	7	8	9	10	11	12	13	14	15	16	17	18
Level 1	SPEED(KM/H)	1	1	2	2	3	3	4	4	4	4	4	4	3	2	2	2	1	1
Level 2	SPEED(KM/H)	1	2	2	2	3	3	4	4	5	4	4	4	3	3	2	2	1	1
Level 3	SPEED(KM/H)	1	2	2	3	3	4	4	5	5	5	4	4	4	3	3	2	1	1
Level 4	SPEED(KM/H)	1	2	3	3	3	4	4	5	6	6	5	4	4	4	3	2	2	1
Level 5	SPEED(KM/H)	1	2	3	4	4	5	5	5	6	6	6	5	4	4	4	3	2	1
Level 6	SPEED(KM/H)	1	2	3	4	5	5	6	6	6	6	6	5	5	4	4	3	2	1
Level 7	SPEED(KM/H)	1	2	3	4	5	6	6	7	7	6	6	6	5	5	4	3	2	1
Level 8	SPEED(KM/H)	1	2	3	4	5	6	7	7	7	7	6	6	6	5	5	4	2	1

P3. FAT BURN

SPEED & INCLINE CHANGES		1	2	3	4	5	6	7	8	9	10	11	12	13	14	15	16	17	18
Level 1	ELEVATION	1	1	2	2	3	3	4	5	5	5	5	4	4	3	2	2	1	1
	SPEED(KM/H)	1	2	3	3	5	6	7	8	8	8	8	7	7	5	4	3	2	1
Level 2	ELEVATION	1	1	2	2	3	4	5	6	6	6	6	5	5	4	3	2	1	1
	SPEED(KM/H)	1	2	3	4	6	7	8	9	9	9	9	8	8	6	5	3	2	1
Level 3	ELEVATION	1	1	2	3	4	5	6	7	7	7	7	6	6	4	3	2	1	1
	SPEED(KM/H)	1	2	4	5	7	8	9	10	10	10	10	9	9	7	6	4	2	1
Level 4	ELEVATION	1	2	3	4	5	6	7	8	8	8	8	7	7	5	4	3	2	1
	SPEED(KM/H)	2	3	5	6	8	9	10	11	11	11	11	10	10	8	7	5	3	2
Level 5	ELEVATION	1	2	3	4	6	7	8	9	9	9	9	8	8	6	5	3	2	1
	SPEED(KM/H)	2	4	6	7	9	10	11	12	12	12	12	11	11	9	8	6	4	2
Level 6	ELEVATION	2	3	4	5	7	8	9	10	10	10	10	9	9	7	6	4	3	2
	SPEED(KM/H)	3	5	7	8	10	11	12	13	13	13	13	12	12	10	9	7	5	3
Level 7	ELEVATION	2	3	5	6	8	9	10	11	11	11	11	10	10	8	7	5	3	2
	SPEED(KM/H)	4	6	8	9	11	12	13	14	14	14	14	13	13	11	10	8	6	4
Level 8	ELEVATION	2	4	6	7	9	10	11	12	12	12	12	11	11	9	8	6	4	2
	SPEED(KM/H)	4	7	9	10	12	13	14	15	15	15	15	14	14	12	11	9	7	4

P5. INTERVAL

SPEED CHANGES		1	2	3	4	5	6	7	8	9	10	11	12	13	14	15	16	17	18
Level 1	SPEED(KM/H)	1	2	4	2	4	2	4	2	4	2	4	2	4	2	4	2	4	2
Level 2	SPEED(KM/H)	1	2	5	2	5	2	5	2	5	2	5	2	5	2	5	2	5	2
Level 3	SPEED(KM/H)	1	2	6	2	6	2	6	2	6	2	6	2	6	2	6	2	6	2
Level 4	SPEED(KM/H)	1	3	6	3	6	3	6	3	6	3	6	3	6	3	6	3	6	3
Level 5	SPEED(KM/H)	1	3	7	3	7	3	7	3	7	3	7	3	7	3	7	3	7	3
Level 6	SPEED(KM/H)	2	4	7	4	7	4	7	4	7	4	7	4	7	4	7	4	7	4
Level 7	SPEED(KM/H)	2	4	8	4	8	4	8	4	8	4	8	4	8	4	8	4	8	4
Level 8	SPEED(KM/H)	2	5	8	5	8	5	8	5	8	5	8	5	8	5	8	5	8	5

P6. ROLLING

SPEED CHANGES		1	2	3	4	5	6	7	8	9	10	11	12	13	14	15	16	17	18
Level 1	SPEED(KM/H)	1	2	3	2	1	2	3	2	1	2	3	2	1	2	3	2	1	1
Level 2	SPEED(KM/H)	2	3	4	3	2	3	4	3	2	3	4	3	2	3	4	3	2	2
Level 3	SPEED(KM/H)	2	3	4	5	4	3	4	5	4	3	4	5	4	3	4	5	4	3
Level 4	SPEED(KM/H)	2	4	5	6	5	4	5	6	5	4	5	6	5	4	5	6	5	3
Level 5	SPEED(KM/H)	2	5	6	7	6	5	6	7	6	5	6	7	5	6	7	6	5	3
Level 6	SPEED(KM/H)	3	6	7	8	7	6	7	8	7	6	7	8	7	6	7	8	7	4
Level 7	SPEED(KM/H)	3	7	8	9	8	7	8	9	8	7	8	9	8	7	8	9	8	4
Level 8	SPEED(KM/H)	3	8	9	10	9	8	9	10	9	8	9	10	9	8	9	10	8	4

OPERATION GUIDE

P7. MOUNTAIN CLIMB

SPEED & INCLINE CHANGES		1	2	3	4	5	6	7	8	9	10	11	12	13	14	15	16	17	18
Level 1	ELEVATION	0	1	1	2	2	3	3	4	4	5	6	7	8	7	6	4	2	0
	SPEED(KM/H)	1	1	2	2	3	3	3	4	4	4	3	3	3	2	2	2	1	1
Level 2	ELEVATION	0	1	2	2	3	3	4	4	5	6	7	8	9	8	6	4	2	0
	SPEED(KM/H)	1	1	2	2	3	3	3	4	4	4	3	3	3	2	2	2	1	1
Level 3	ELEVATION	1	1	2	3	3	4	4	5	6	7	8	9	10	9	8	6	4	2
	SPEED(KM/H)	1	1	2	2	3	3	3	4	4	4	3	3	3	2	2	2	1	1
Level 4	ELEVATION	1	2	2	3	3	4	5	6	7	8	9	10	11	10	8	7	5	3
	SPEED(KM/H)	2	2	3	3	4	4	4	5	5	4	4	4	3	3	3	2	2	2
Level 5	ELEVATION	1	2	3	4	5	6	7	8	9	9	10	11	12	11	10	8	6	4
	SPEED(KM/H)	2	2	3	3	4	4	4	5	5	4	4	4	3	3	3	2	2	2
Level 6	ELEVATION	2	2	3	4	5	6	7	8	9	10	11	12	13	12	10	8	6	4
	SPEED(KM/H)	2	2	3	3	4	4	4	5	5	4	4	4	3	3	3	2	2	2
Level 7	ELEVATION	2	3	4	5	6	7	8	9	10	11	12	13	14	13	10	8	6	4
	SPEED(KM/H)	2	2	4	4	5	5	5	6	6	6	5	5	4	4	4	2	2	2
Level 8	ELEVATION	3	4	5	6	7	8	9	10	11	12	13	14	15	13	10	8	6	4
	SPEED(KM/H)	2	2	4	4	5	5	5	6	6	6	5	5	4	4	4	2	2	2

P8. HILL RUN

SPEED & INCLINE CHANGES		1	2	3	4	5	6	7	8	9	10	11	12	13	14	15	16	17	18
Level 1	ELEVATION	0	0	1	1	2	2	2	3	3	3	4	4	5	5	4	3	2	1
	SPEED(KM/H)	2	2	2	3	3	3	5	5	7	7	9	9	10	8	8	6	4	2
Level 2	ELEVATION	0	0	1	1	2	2	2	3	3	3	4	4	5	6	5	3	2	1
	SPEED(KM/H)	2	2	2	4	4	4	6	6	6	8	8	10	10	8	8	6	4	2
Level 3	ELEVATION	0	0	1	1	2	2	3	3	3	4	4	5	5	6	5	3	2	1
	SPEED(KM/H)	2	2	4	4	4	6	6	6	8	8	10	10	12	10	8	6	4	2
Level 4	ELEVATION	0	1	1	2	2	3	3	4	4	4	5	5	6	7	6	5	3	2
	SPEED(KM/H)	2	2	4	4	6	6	8	8	8	10	10	10	12	12	10	7	5	3
Level 5	ELEVATION	1	1	2	2	3	3	4	4	5	5	6	6	7	8	7	6	3	2
	SPEED(KM/H)	2	4	6	6	6	6	8	8	8	10	10	12	13	12	10	7	5	3
Level 6	ELEVATION	1	2	3	4	4	4	5	5	6	6	7	8	8	8	7	6	3	2
	SPEED(KM/H)	2	4	6	6	6	6	8	8	10	10	12	13	13	12	10	7	5	3
Level 7	ELEVATION	1	2	3	4	5	6	6	7	7	8	8	9	10	10	9	6	3	2
	SPEED(KM/H)	2	4	6	6	8	8	10	10	12	13	13	14	13	12	10	7	5	3
Level 8	ELEVATION	1	2	3	4	6	6	7	7	8	8	9	9	10	12	9	6	3	2
	SPEED(KM/H)	2	4	6	8	10	10	12	12	13	13	14	14	13	12	10	7	5	3

HOW TO FOLD THE TREADMILL

Before folding the treadmill, lower the treadmill to 0 incline level and then unplug the power cord.

CAUTION: You must be able to safely lift 45 pounds (20kg) in order to raise, lower, or move the treadmill.

1. Hold the treadmill with your hands in the locations shown at the right. **CAUTION: To decrease the possibility of injury, bend your legs and keep your back straight. As you raise the treadmill, make sure to lift with your legs rather than your back.** Raise the treadmill until the running deck is firmly held by the folding pole as the right figure shows.

2. If you want to put the treadmill to the work position, Firstly pull the folding knob outward as figure shows, And then lay down the running deck light onto floor.

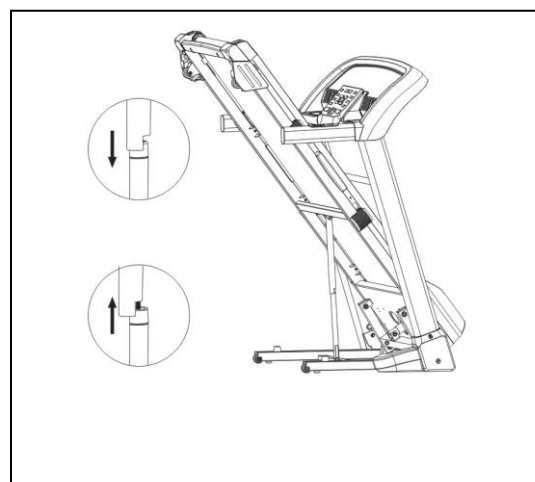
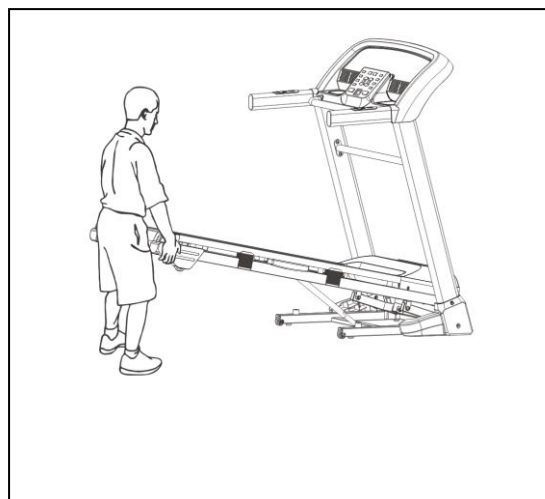

HOW TO MOVE THE TREADMILL

1. Hold the handrails as shown and place one foot against a wheel.

2. Tilt the treadmill back until it rolls freely on the wheels. Carefully move the treadmill to the desired location.

Never move the treadmill without tipping it back. To reduce the risk of injury, use extreme caution While moving the treadmill. Do not attempt to move the treadmill over an uneven surface.

3. Place one foot on a wheel, and carefully lower the Treadmill until it is resting in the storage position.



SUGGESTED STRETCHES

A successful exercise program consists of a warm-up, aerobic exercise, and a cool-down. Do the entire program at least two and preferably three times a week, resting for a day between workouts. After several months, you can increase your workouts to four or five times per week.

Warming up is an important part of your workout, and should begin every session. It prepares your body for more strenuous exercise by heating up and stretching out your muscles, increasing your circulation and pulse rate, and delivering more oxygen to your muscles. At the end of your workout, repeat these exercises to reduce sore muscle problems. We suggest the following warm-up and cool-down exercises:

1. Inner Thigh Stretch

Sit with the soles of your feet together with your knees pointing outward. Pull your feet as close into your groin as possible. Gently push your knees towards the floor. Hold for 15 counts.



2. Hamstring Stretch

Sit with your right leg extended. Rest the sole of your left foot against your right inner thigh. Stretch toward your toe as far as possible. Hold for 15 counts. Relax and then repeat with left leg extended.



3. Head Roll

Rotate your head to the right for one count, feeling the stretch up the left side of your neck. Next, rotate your head back for one count, stretching your chin to the ceiling and letting your mouth open. Rotate your head to the left for one count, and finally, drop your head to your chest for one count.



4. Shoulder Lift

Lift your right shoulder up toward your ear for one count. Then lift your left shoulder up for one count as you lower your right shoulder.



5. Toe Touch

Slowly bend forward from your waist, letting your back and Shoulders relax as you stretch toward your toes.

Reach down as far as you can and hold for 15 counts.



6. Calf-Achilles Stretch

Lean against a wall with your left leg in front of the right and your arms forward. Keep your right leg straight and the left foot on the floor; then bend the left leg and lean forward by moving your hips toward the wall. Hold, and then repeat on the other side for 15 counts.



7. Side Stretch

Open your arms to the side and continue lifting them until they are over your head.

Reach your right arm as far upward toward

The ceiling as you can for one count.

Feel the stretch up your right side.

Repeat this action with your left arm.



MAINTENANCE

WARNING! Before performing any maintenance to your treadmill, always unplug the power cord from the surge protector.

CLEANING: Routine cleaning of your TREADMILL will extend the life of your treadmill.

WARNING! To prevent electrical shock, be sure the power to the treadmill is OFF and the unit is unplugged from the wall electrical outlet before attempting any cleaning or maintenance.

AFTER EACH WORKOUT: Wipe off the console and other treadmill surfaces with a clean, water dampened soft cloth to remove excess perspiration. **USE NO CHEMICALS.**

WEEKLY: Use of a treadmill mat is recommended for ease of cleaning. Dirt from your shoes contacts the belt and eventually ends up underneath the treadmill. Vacuum underneath the treadmill once a week.

DECK LUBRICATION: The walking belt has been pre-lubricated at the factory. However, it is recommended that the walking board be checked periodically for lubrication to ensure optimal treadmill performance. Every 10 days or 10 hours of operation, lift the sides of the walking belt and feel the top surface of the walking board as far under as you can reach. If you feel signs of silicone, no further lubrication is required. If it feels dry to the touch, lubrication is needed. Ask your retailer or call Service line for the type of silicone.

TO APPLY LUBRICANT TO THE WALKING BOARD

- 1) Position the walking belt so that the seam is located on top and in the center of the center of the walking board.
- 2) Insert the spray nozzle into the spray head of the lubricant can.
- 3) While lifting the side of the walking belt, position the spray nozzle between the walking belt and the board approximately 10cm from the front of the treadmill. Apply the silicone spray to the walking board, moving from the front of the treadmill to the rear. Repeat this on the other side of the belt. Spray approximately 4 seconds on each side.
- 4) Allow the silicone to 'set' for one minute before using the treadmill.

WARNING: Do not over-lubricate the walking board. Excess lubricant should be wiped off with a clean towel

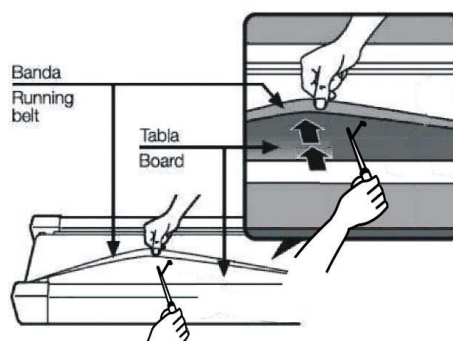

Running belt tension adjustment

The treadmill has been adjusted and passed QC inspection before leaving the factory. If there is phenomenon of bias running of the belt, the possible reasons might be:

- A. The frame is not stably laid
- B. The user is not running on the center of the running belt;
- C. The user's two feet are not using even strength.

For bias which cannot be fixed automatically, try the following methods to fix the belt, as picture shown

If the belt tends to move to the right, you should turn the belt adjustment screw on the right in clockwise direction. We recommend you turn 1/4 turn each time and check how it works. If the belt remains slanting to the right, then turn the belt adjustment screw on the left in counterclockwise direction 1/4, as shown in the picture A

If the belt tends to move to the left, then turn the belt adjustment screw on the left in clockwise direction for 1/4 turn. If the belt remains slanting to the left, then turn the belt adjustment screw on the right in counterclockwise direction for 1/4 turn, as shown in the picture B

After having been used for a period, the belt might be slightly elongated, and slipping and halting might appear when a person is running on it. When these phenomena appear, you should secure the screws on both sides for 1/4 turn. If the belt is too tight, just loosen the screw on both sides for 1/4 turn, as shown in picture C.

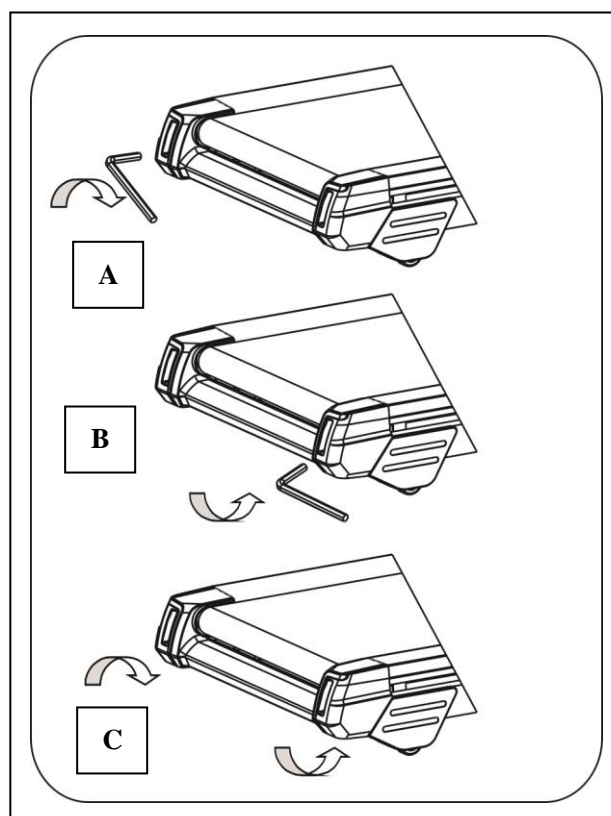

EXPLODED DRAWING

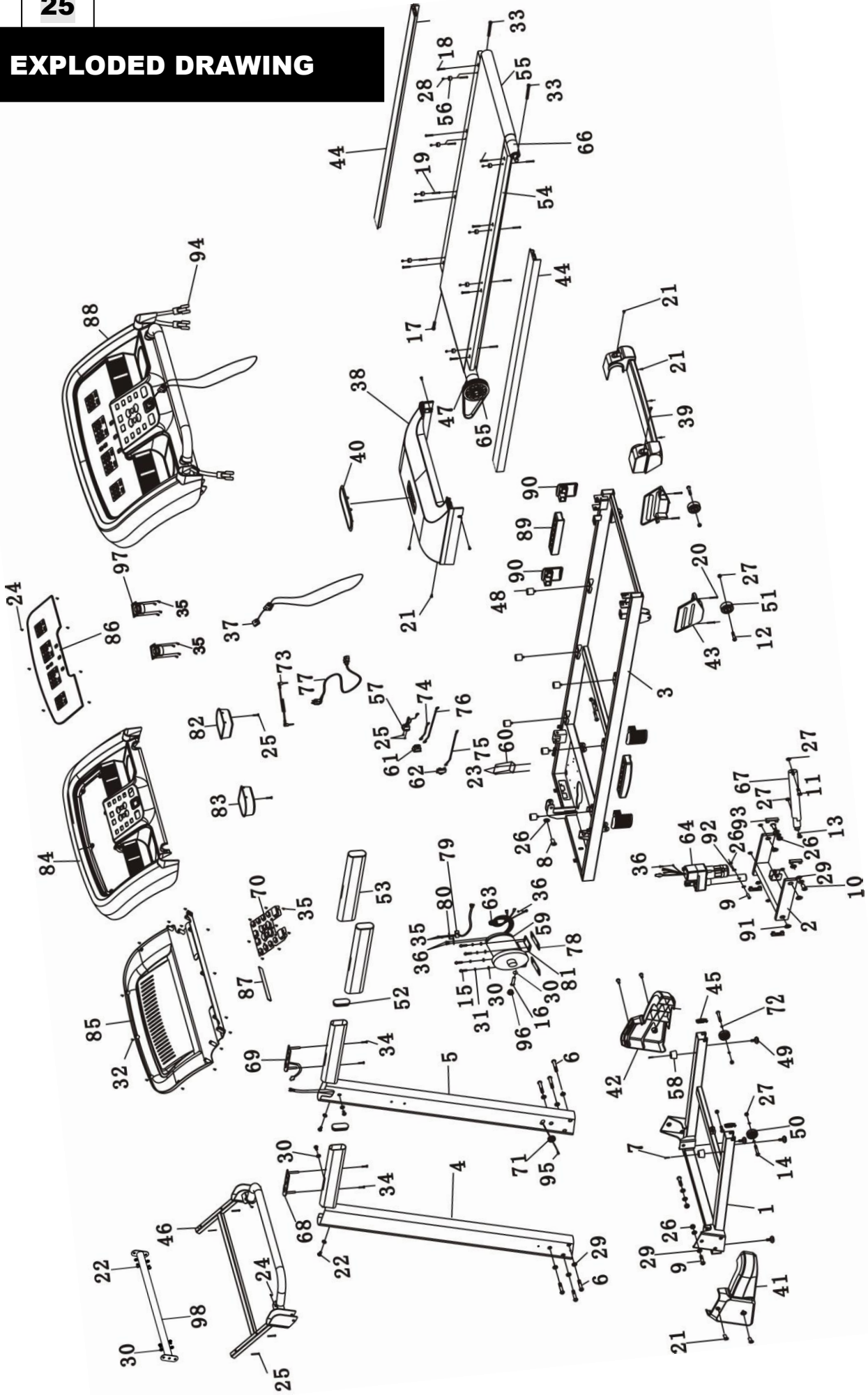

PART LIST

NO.	DESCRIPTION	Q'TY	NO.	DESCRIPTION	Q'TY
1	BASE	1	50	BASE WHEEL ϕ 44*18* ϕ 8.5	2
2	INCLINE RACK	1	51	FRAME WHEEL ϕ 51*22* ϕ 8.5	2
3	MAIN FRAME	1	52	HANDRAIL END CAP	2
4	LEFT UPRIGHT	1	53	HANDRAIL FOAM	2
5	RIGHT UPRIGHT	1	54	RUNNING DECK	1
6	BOLT M10*50	6	55	RUNNING BELT	1
7	SCREW M6*20	2	56	FOOT RAIL FASTENER	6
8	BOLT M10*60	1	57	POWER CORD JACK	1
9	BOLT M10*40	3	58	BASE CUSHION	2
10	BOLT M10*45	2	59	DC MOTOR	1
11	BOLT M8*45	1	60	CONTROLLER	1
12	BOLT M8*40	2	61	POWER SWITCH	1
13	BOLT M8*28	1	62	CIRCUIT BREAKER	1
14	BOLT M8*50	2	63	MAGNETIC RING	1
15	BOLT M8*15	4	64	INCLINE MOTOR	1
16	BOLT M8*100	1	65	FRONT ROLLER	1
17	BOLT M8*55	1	66	REAR ROLLER	1
18	SCREW M6*25	8	67	AIR CYLINDER	1
19	SCREW M5*28	8	68	HANDRAIL BUTTON-LEFT	1
20	SCREW M6*10	4	69	HANDRAIL BUTTON-RIGHT	1
21	SCREW M5*12	12	70	KEY PAD	1
22	SCREW M8*15	8	71	CABLE GROMMET	1
23	SCREW M4*12	6	72	STOP COLLAR	2
24	SCREW M4*10	9	73	AUDIO CABLE	1
25	SCREW M4*30	4	74	AC CABLE L=400 BLACK	1
26	NUT M10	6	75	AC CABLE L=400 RED	1
27	NUT M8	6	76	AC CABLE L=100 RED	1
28	NUT M5	8	77	POWER CORD	1
29	FLAT WASHER M10	14	78	MOTOR RUBBER PAD	2
30	FLAT WASHER M8	13	79	PHOTONIC SENSOR	1
31	SPRING WASHER M8	4	80	SENSOR BRACKET	1
32	SCREW M4*12	14	81	MOTOR BASE	1
33	BOLT M8*65	2	82	BOTTLE HOLDER-RIGHT	1
34	SCREW M4*35	4	83	BOTTLE HOLDER-LEFT	1
35	SCREW M3*6	22	84	CONSOLE PLASTIC HOUSING-UPPER	1
36	SCREW M4*8	4	85	CONSOLE PLASTIC HOUSING-BOTTOM	1
37	SAFETY KEY	1	86	COMPUTER PLASTIC	1
38	MOTOR COVER	1	87	SILICON PAD	1
39	REAR END CAP	1	88	COMPUTER SET	1
40	BRAND STICKER HOLDER	1	89	AIR CUSHION	2
41	BASE COVER-LEFT	1	90	SPRING CUSHION	4
42	BASE COVER-RIGHT	1	91	PLASTIC BUSHION(INCLINE RACK)	4
43	FRAME WHEEL COVER	2	92	PLASTIC BUSHION(INCLINE MOTOR)	2
44	SIDE RAIL	2	93	BASE CAP	4
45	MOVING WHEEL COVER	2	94	SIGNAL CABLE-1	1
46	CONSOLE RACK	1	95	SIGNAL CABLE-2	1
47	MOTOR BELT	1	96	END CAP	1
48	CUSHION ϕ 20* ϕ 6.5*13	6	97	SPEAKER	1
49	BASE FOOT PAD	4	98	Connecting tube	1

TROUBLE SHOOTING

PROBLEM	POSSIBLE CAUSES	CORRECTION
Console has no display	<ol style="list-style-type: none"> 1. Power cord not plugged well. 2. Defection on whole set cable or not plug well. 3. Overload protection. 	<ol style="list-style-type: none"> 1. Check power cord connection. 2. Plug every connector well. 3. Reset overload protector.
Treadmill belt slipping	<ol style="list-style-type: none"> 1. Running belt too loose. 2. Motor belt too loose. 	<ol style="list-style-type: none"> 1. Tighten running belt. 2. Tighten motor belt.
Running belt not smooth	<ol style="list-style-type: none"> 1. Lack lubrication oil 2. Running belt too tight. 	<ol style="list-style-type: none"> 1. Add lubrication oil to belt and deck. 2. Loose running belt.
Motor not work	<ol style="list-style-type: none"> 1. Safety key not attached correctly. 2. Motor cable not connect well. 3. Whole set cable not plug well. 4. Controller damaged. 5. Motor damaged. 	<ol style="list-style-type: none"> 1. Insert safety key. 2. Check motor cable connection. 3. Plug whole set cable again. 4. Replace controller. 5. Replace motor.