

Orbit STARLITE SL2

SL2

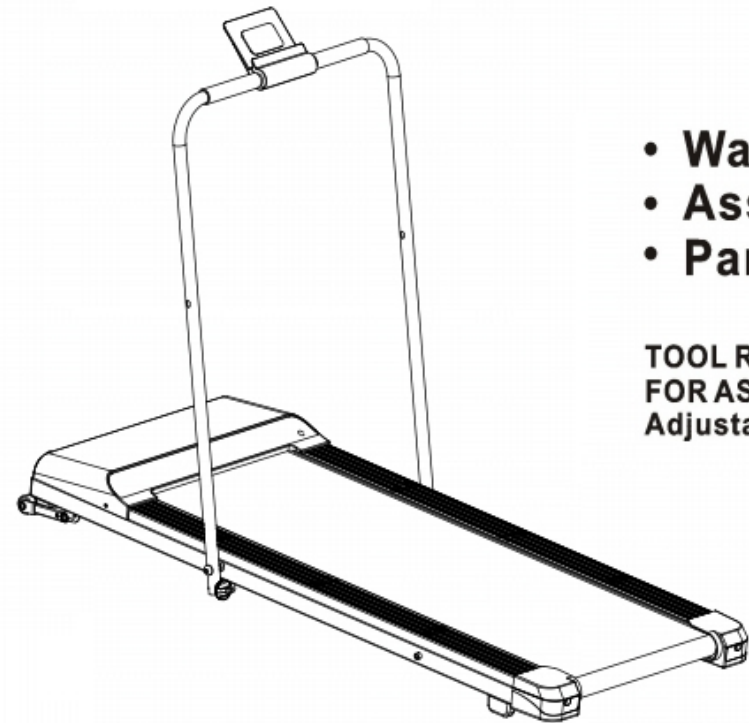

- Warranty
- Assembly
- Parts

**TOOL REQUIRED
FOR ASSEMBLY**
Adjustable Wrench

Owner's manual SL2

CAUTION : 1. Weight on this product should not exceed 90kg/199lbs
2. Exercise of a strenuous nature, as is customarily done on this equipment, should not be undertaken without first consulting a physician. No specific health claims are made or implied as they relate to the equipment.
Measurements made by the equipment are believed to be accurate, but only the measurements of your physician should be relied upon.

IMPORTANT: Read all instructions carefully before using this product. Retain this product. Owner's manual for future reference.

Contents

I. IMPORTANT PRECAUTIONS.....	(1)
II.MAIN TECHNICAL FEATURES	(3)
III. ASSEMBLY	(4)
IV.WORKOUT GUIDELINES	(6)
V.TREADMILL OPERATION.....	(7)
VI. MAINTENANCE.....	(8)
VII. RECYCLING INFORMATION.....	(10)
IX.EXPLODED VIEW and PARTS LIST.....	(11)

No.	ITEM	Description	Qty
1	Handrail tube		1
2	screw	M4×6	1
3	X512F foam	∅31*T3.0*150	2
4	X512F anti-slip sticker	90*55*T2.2	1
5	X512F ipad holder lower cover		1
6	Screw	ST4X13	3
7	X512F ipad holder upper cover		1
8	Screw	M6*10	4
9	gasket	M6	4
10	Upright L		1
11	Nut	M8	2
12	gasket	∅8	2
13	Upright R		1
14	X512F knob	M8*30	2

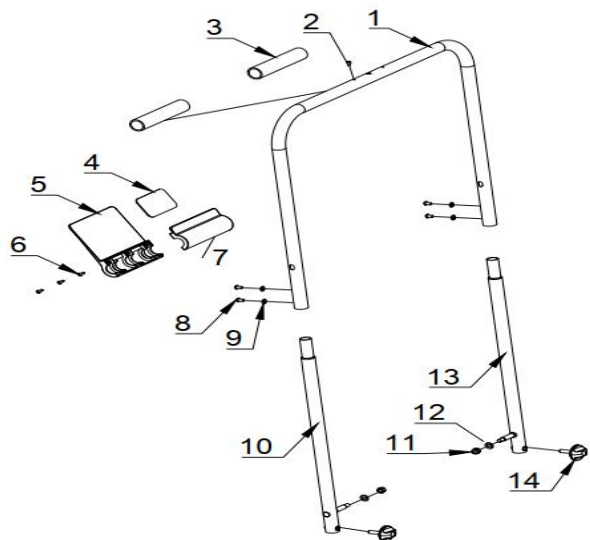

PARTS LIST

No.	ITEM	Description	Qty	No.	ITEM	Description	Qty
1	Side stripe	pvc	2	24	screw	M8*12	1
2	Running belt	410*2520*T1.4	1	25	Spring pad	m8 screw	2
3	Screw	ST4*16	39	26	M8 metal gasket	m8 screw	18
4	upper motor cover		1	27	motor cover fixed plastic parts		5
5	AC connection wire	red	1	28	main steel frame		1
6	screw	ST2.5*6	6	29	rubber Shock absorber cover		4
7	screw	M8*60	3	30	fixed foot pad		2
8	M6 metal gasket	with m6 screw	3	31	AC Bifurcated wire		1
9	front roller		1	32	rear roller		1
10	motor		1	33	screw	M6*50	3
11	motor belt	EPJ427 6	1	34	rear cover R		1
12	main frame front foot pad		2	35	rear cover L		1
13	foot pad		2	36	front foot pad		2
14	spring for folding frame R		1	37	folding frame foot pad		2
15	running board		1	38	screw	M8*40	2
16	slider	φ42*φ15*T5.0	8	39	transportation wheel		2
17	Screw	M8*25	6	40	Nut	M8	4
18	reinforcement tube		1	41	folding frame		1
19	PCB		1	42	X512 LED screen		1
20	AC connection wire	black	1	43	X512 panel sticker		1
21	power switch		1	44	spring for folding frame L		1
22	overload protective device		1	45	lower motor cover		1
23	power cable	0.75mm²	1	46	signal wire		1



IMPORTANT PRECAUTIONS



MINIMUM USER HEIGHT	140 cm	MAX USER WEIGHT	90 kg.
---------------------	--------	-----------------	--------



WARNING:

THE SECURITY KEY HAS A MAGNET WHICH MUST BE PUT IN THE DISPLAY. AT THE END OF THE LACE THERE IS A CLAMP WHICH SHOULD BE ATTACHED TO THE CLOTHES.THE TREADMILL WILL START WORKING ONLY IF THE KEY IS PLACED IN THE DISPLAY.THIS IS ESSENTIAL.

A CORRECT LUBRICATION OF THE TREADMILL WITH SILICON OIL OR TEFLON IS REALLY IMPORTANT. THIS LUBRICATION MUST BE PERFORMED REGULARLY DEPENDING ON EACH PERSON, EVEN BEFORE ITS FIRST USE.

YOU MUST PRESERVE THE ORIGINAL PACKAGING WITH ITS PROTECTIONS, PURCHASE RECEIPT, MANUAL AND COMPONENTS DURING THE GUARANTEE PERIOD.

In order to decrease the risk of suffering severe injuries, read carefully all the important instructions and warnings regarding the use of a treadmill before using it.

EVOLUTION FITNESS doesn't take any responsibility for personal injuries or property damages resulting from the use of this product.

1-Before starting any workout program, consult your doctor. It's specially important for people older than 35 years old, people with health problem and pregnant women.

2-The owner must ensure that all users are correctly informed about the warnings.

3-Use the equipment as explained in the instructions manual.

4-Keep the equipment in an enclosed area, away from dust or humidity. Don't store it in a garage, indoor backyard or near the water. Humidity, dust and water could lead to a malfunction of the equipment, annulling its guarantee.

5-Place the unit on a flat surface. If the surface is uneven, the proper functioning could be affected. Some models include levellers or levelling threads behind the legs, helping the levelling. Please read the manual to verify if your unit is provided with one of them..

- **CLEANING:** Don't use abrasive products. A damp cloth is enough.
- **LEVELING:** If your unit is provided with leveling wheels, please adjust them in order to avoid vibrations and therefore malfunctions.
- **KEEP THESE MAINTENANCE ADVISES FOR FUTURE REFERENCES**

VII.RECYCLING INFORMATION

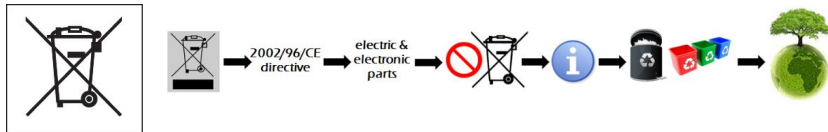

This electronic product must not be disposed of in municipal waste. To preserve the environment, this product must be recycled after its useful life as required by law.



A correct lubrication of the treadmill with silicon oil or teflon is REALLY IMPORTANT. This lubrication MUST BE PERFORMED REGULARLY DEPENDING ON EACH PERSON, EVEN BEFORE ITS FIRST USE.

YOU MUST PRESERVE THE ORIGINAL PACKAGING WITH ITS PROTECTIONS, PURCHASE RECEIPT, MANUAL AND COMPONENTS DURING THE GUARANTEE PERIOD

24-Do a workout with stretches before and after the sessions, you will avoid injuries.

25-Drink water before, during and after the workout.

26-If you start feeling pain or dizziness while training: **STOP IMMEDIATELY.**

27-**YOU MUST PRESERVE THE ORIGINAL PACKAGING WITH ITS PROTECTIONS, MANUAL AND COMPONENTS DURING THE GUARANTEE PERIOD.**

28-The accessories can be different to the other models.

29-This electronic product can't be thrown under any circumstances into the municipal rubbish bins. With the aim of preserving the environment, this product must be recycled according to the applicable law of your country. Please contact your town council to know more about this procedure.

30-Should you need technical assistance or advise with the installation of pieces, You can get in touch with us by email :-.....-

**YOU MUST KEEP THE PURCHASE RECEIPT IN ORDER TO HAVE ACCESS TO THIS SERVICE
KEEP THESE ADVISES FOR FUTURE REFERENCES**

II.MAIN TECHNICAL FEATURES

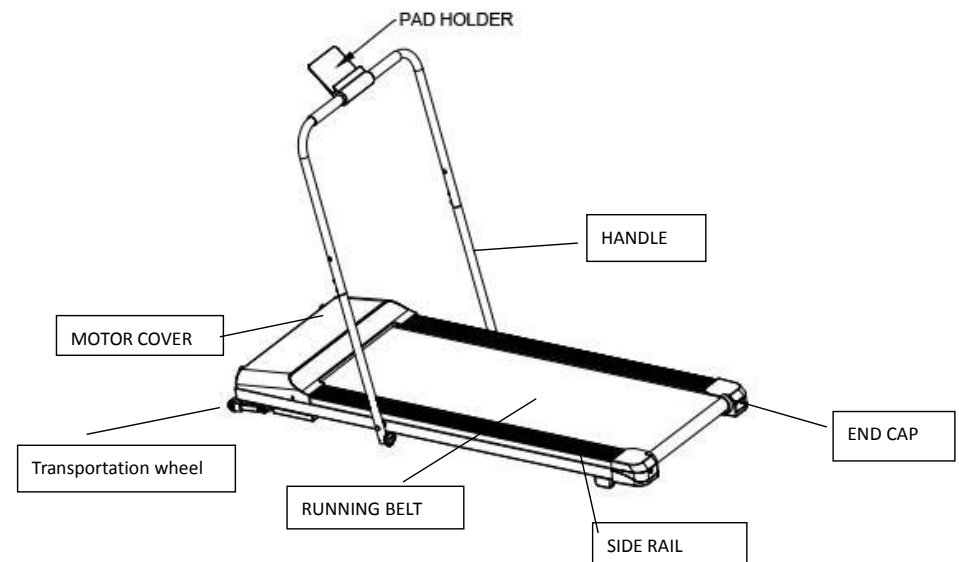

Input Voltage	220V±10%
Frequency	50/60 Hz
Running area	1150X410mm
Function	Time, Speed, Remote controller ,Bluetooth APP
Speed Range	1.0-6.0KM/H
Max user weight	90kgs
Power	1.5HP

III.ASSEMBLY



NOTICE:ASSEMBLY REQUIRES TWO PERSONS

No.	Fittings	Qty
1	remote controller	1
2	Silicone oil	1
3	5mm wrench	1
4	6mm wrench	1
5	Multi- wrench	1
6	M6*10 screws	2
7	M6 washers	2
8	Lock screws	2

STEP 1

1. Carry out the machine from the package by two persons and place it lightly on flat floor, and put other fittings beside the machine.
2. Put the handrail on running deck frame and lock it with 2pcs M6*10 screws and flats at both sides.

• ALIGN AND TIGHTEN THE BELT OF THE TREADMILL

ALIGN THE BELT: Due to its use, the belt can move off center. If the belt has moved to the left, start treadmill and increase the speed to 3KM/H .Use the 5mm Wrench to turn the fixed left bolt clockwise or turn the fixed right bolt counterclockwise. Don't tighten the belt too much in order to be able to walk. Repeat this procedure until the belt is properly aligned.

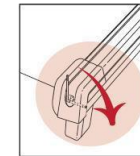
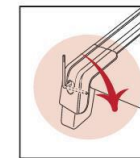
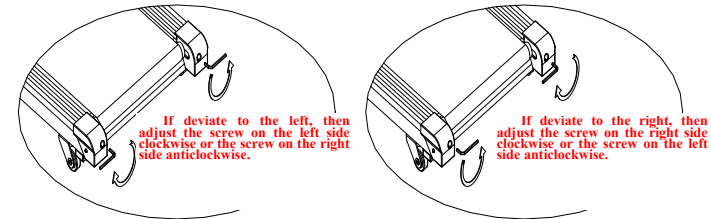

- **TIGHTEN THE BELT:** (if the belt slips on the treadmill when walking). Start treadmill and increase the speed to 3MPH.Using the 5mm Wrench , turn both bolts 1/4 clockwise. If the belt is properly tight to walk, you must be able to pull up each side of the belt 5 or 7 cm off the platform. Be careful and maintain the belt aligned. Repeat this procedure until the belt is properly tightened.

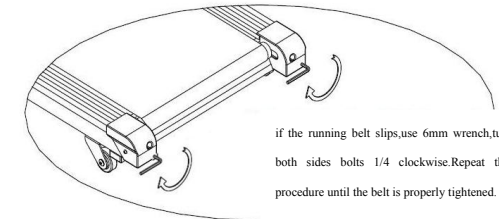

if the running belt slips,use 6mm wrench,turn both sides bolts 1/4 clockwise.Repeat this procedure until the belt is properly tightened.

- **TIGHTEN THE DRIVE BELT:**if the drive belt becomes loose after using for a period of time,you need to:
 - (1) Open the motor cover .
 - (2) Use the 5mm wrench to turn the adjusting bolt clockwise.
 Repeat this procedure until the drive belt is not slippery anymore.

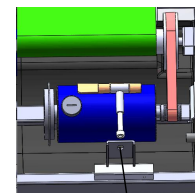

Adjusting bolt

VI. MAINTENANCE

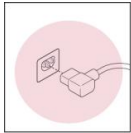

This product must be earthed. If the power cord is damaged, it must be replaced with a manufacturer recommended power cord.

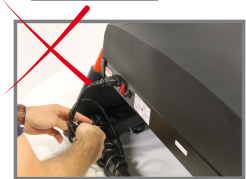
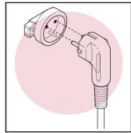

DO NOT TANGLE THE POWER CORD

REGULAR MAINTENANCE OF THE TREADMILL

- **STORAGE:** Keep your equipment in an enclosed place, away from dust or humidity. Don't store it in a garage or in an indoor backyard, or near the water. Humidity, dust and water could damage it and have an effect on its functioning
- **ELECTRIC CABLE:** Make sure that the cable and plug are in perfect conditions. Electric cables must be away from hot surfaces
- **SCREWS AND CONNECTING CABLES:** Supervise and tighten the screws on a regular basis, because due to the vibration the screws and nuts tend to loosen.

LUBRICATION:

Whether it is necessary to lubricate, make sure the machine is switched off and unplug the electricity. Lift the running belt, observe if there are any silicon remaining on the running board which is under the running belt. If it is dry, then you need to apply the lubricant.



- The step to lubricate the running board is as follows: (see the right figure)
- Stop the running belt and fold the treadmill.
- Turn over the running belt at the back of the mainframe. Insert the lubricant pot as deep as possible into the middle of the running belt. Apply the lubricant onto the inner side of the running belt. Lubricate both sides of the running belt.

After the lubrication is completed, start the machine at 1km/h to let the running belt bring silicon all over the board.

< 3 hours/week	2 months
4 - 7 hours/week	1 month
> 8 hours/week	15 days

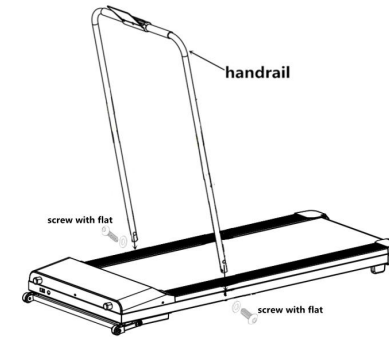

STEP 2

- Put the 2 pcs lock screws at both sides to make sure handrail not shakable.
- Adjust the pad holder to right angle, then plug on and turn on power to use treadmill.

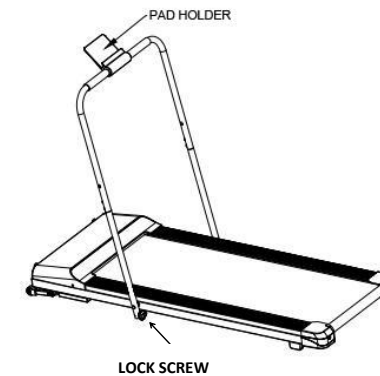

STEP 3

When not use the handle, unlock the bottom screws and fall down as A direction shows, lock the handle to the main frame, and turn the pad holder to running board.

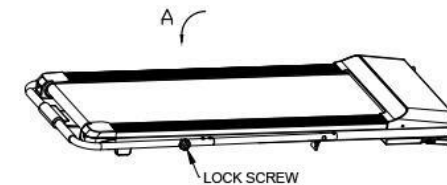

STEP 4

When not use the treadmill, please fold the machine in A direction until the transportation wheels pop up in B direction.

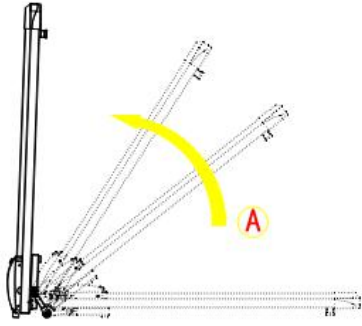

IV.WORKOUT GUIDELINES

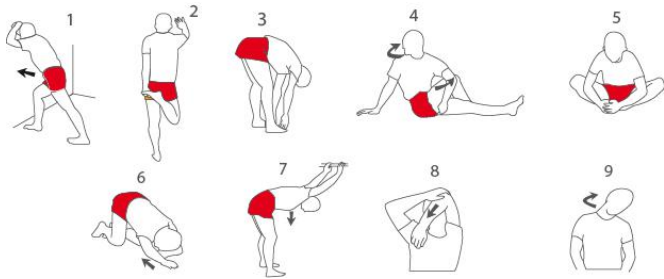

BEWARE: Before starting to use this or any exercise programs, consult your doctor. This is specially important for people older than 35 years old, or for people with health problems.

If your equipment is provided with a pulse sensor, you must keep in mind this isn't a medical instrument. Several factors can vary the accuracy of the heart rate interpretations. The pulse sensor is just a help for the work outs, determining the general tendencies of the heart rate.

PROGRAMM WITH WARM UP WORKOUTS:

WARM UP: Start stretching and slightly activating the muscles between 5 and 10 minutes. The warm up will increase your corporal temperature, your heart rate and your blood flow, making you ready for the workouts.

- **WORKOUT FOCUSED ON THE TRAINING AREA:** Do some exercises during 20-30 minutes with your heart rate (don't maintain your heart rate more than 20 minutes during the first weeks of the exercise program). Breath constantly and deeply during the workout (never hold your breath).

- **COOL DOWN:** Finish with stretching exercises during 5-10 minutes. Stretching increases the flexibility of your muscles and help you to avoid injuries after the workouts.

FREQUENCY OF THE WORKOUT: In order to be fit or improve your shape, complete three workout sessions each week, with a rest day between the workouts. After some moths of regular training, you will be able of completing up to five workouts a week.

V.TREADMILL OPERATION

REMOTE CONTROL

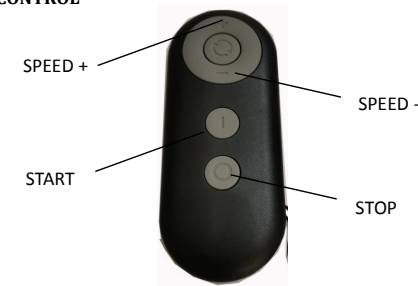

1. LED display: Speed range 1 KM - 6 KM.
2. Press "Speed +" key, speed will go up by 0.5 km.
3. Press "Speed -" key, speed will go down by 0.5 km.
4. Press "Start" key to start machine.
5. Press "Stop" key to stop machine.

APP GFIT

Download app "Gfit" and login in, can control the machine on app through bluetooth.

